

PCM-3370

**LV Intel Pentium III/ ULV Celeron
PC/104+ CPU Module**

User's Manual

Copyright

This document is copyrighted, © 2003. All rights are reserved. The original manufacturer reserves the right to make improvements to the products described in this manual at any time without notice.

No part of this manual may be reproduced, copied, translated or transmitted in any form or by any means without the prior written permission of the original manufacturer. Information provided in this manual is intended to be accurate and reliable. However, the original manufacturer assumes no responsibility for its use, nor for any infringements upon the rights of third parties that may result from such use.

Acknowledgements

Award is a trademark of Award Software International, Inc.

VIA is a trademark of VIA Technologies, Inc.

IBM, PC/AT, PS/2 and VGA are trademarks of International Business Machines Corporation.

Intel and Pentium are trademarks of Intel Corporation.

Microsoft Windows® is a registered trademark of Microsoft Corp.

RTL is a trademark of Realtek Semi-Conductor Co., Ltd.

ESS is a trademark of ESS Technology, Inc.

UMC is a trademark of United Microelectronics Corporation.

SMI is a trademark of Silicon Motion, Inc.

Creative is a trademark of Creative Technology LTD.

All other product names or trademarks are properties of their respective owners.

For more information on this and other Advantech products, please visit our websites at: **<http://www.advantech.com>**

<http://www.advantech.com/epc>

For technical support and service, please visit our support website at:

<http://support.advantech.com>

Part No. 2006337001

2nd Edition, April 2004

Packing List

Before you begin installing your card, please make sure that the following materials have been shipped:

- 1 PCM-3370 all-in one single board computer
- 1 CD-ROM or disks for utility, drivers, and manual (in PDF format)
- 1 warranty certificate
- 1 2.5" IDE flat cable, 44-pin to 44-pin (product no. 1701440350)
- 1 PS/2 keyboard & mouse cable (product no. 1700060202)
- 2 serial port cables (product no. 1700100250)
- 1 Y-cable external cable (product no. 1703060053)
- 1 parallel cable (product no. 1700260250)
- 1 VGA cable (product no. 1701160150)
- 1 LAN cable (product no. 1701100202)
- ATX power cable (product no. 1703200380)

If any of these items are missing or damaged, contact your distributor or sales representative immediately.

Additional Information and Assistance

Step 1. Visit the Advantech web site at **www.advantech.com** where you can find the latest information about the product.

Step 2. Contact your distributor, sales representative, or Advantech's customer service center for technical support if you need additional assistance. Please have the following information ready before you call:

- Product name and serial number
- Description of your peripheral attachments
- Description of your software (operating system, version, application software, etc.)
- A complete description of the problem
- The exact wording of any error messages

Safety Instructions

1. Read these safety instructions carefully.
2. Keep this User's Manual for later reference.
3. Disconnect this equipment from any AC outlet before cleaning. Use a damp cloth. Do not use liquid or spray detergents for cleaning.
4. For plug-in equipment, the power outlet socket must be located near the equipment and must be easily accessible.
5. Keep this equipment away from humidity.
6. Put this equipment on a reliable surface during installation. Dropping it or letting it fall may cause damage.
7. The openings on the enclosure are for air convection. Protect the equipment from overheating. **DO NOT COVER THE OPENINGS.**
8. Make sure the voltage of the power source is correct before connecting the equipment to the power outlet.
9. Position the power cord so that people cannot step on it. Do not place anything over the power cord.
10. All cautions and warnings on the equipment should be noted.
11. If the equipment is not used for a long time, disconnect it from the power source to avoid damage by transient overvoltage.
12. Never pour any liquid into an opening. This may cause fire or electrical shock.
13. Never open the equipment. For safety reasons, the equipment should be opened only by qualified service personnel.
14. If one of the following situations arises, get the equipment checked by service personnel:
 - a. The power cord or plug is damaged.
 - b. Liquid has penetrated into the equipment.
 - c. The equipment has been exposed to moisture.
 - d. The equipment does not work well, or you cannot get it to work according to the user's manual.
 - e. The equipment has been dropped and damaged.
 - f. The equipment has obvious signs of breakage.
15. **DO NOT LEAVE THIS EQUIPMENT IN AN ENVIRONMENT WHERE THE STORAGE TEMPERATURE MAY GO BELOW -20° C (-4° F) OR ABOVE 60° C (140° F). THIS COULD DAMAGE THE EQUIPMENT. THE EQUIPMENT SHOULD BE IN A CONTROLLED ENVIRONMENT.**
16. **CAUTION: DANGER OF EXPLOSION IF BATTERY IS INCORRECTLY REPLACED. REPLACE ONLY WITH THE SAME OR EQUIVALENT TYPE RECOMMENDED BY THE MANUFACTURER, DISCARD USED BATTERIES ACCORDING TO THE MANUFACTURER'S INSTRUCTIONS.**

The sound pressure level at the operator's position according to IEC 704-1:1982 is no more than 70 dB (A).

DISCLAIMER: This set of instructions is given according to IEC 704-1. Advantech disclaims all responsibility for the accuracy of any statements contained herein.

Wichtige Sicherheitshinweise

1. Bitte lesen sie Sich diese Hinweise sorgfältig durch.
2. Heben Sie diese Anleitung für den späteren Gebrauch auf.
3. Vor jedem Reinigen ist das Gerät vom Stromnetz zu trennen. Verwenden Sie Keine Flüssig-oder Aerosolreiniger. Am besten dient ein angefeuchtetes Tuch zur Reinigung.
4. Die Netzanschlussteckdose soll nahe dem Gerät angebracht und leicht zugänglich sein.
5. Das Gerät ist vor Feuchtigkeit zu schützen.
6. Bei der Aufstellung des Gerätes ist auf sicheren Stand zu achten. Ein Kippen oder Fallen könnte Verletzungen hervorrufen.
7. Die Belüftungsöffnungen dienen zur Luftzirkulation die das Gerät vor überhitzung schützt. Sorgen Sie dafür, daß diese Öffnungen nicht abgedeckt werden.
8. Beachten Sie beim Anschluß an das Stromnetz die Anschlußwerte.
9. Verlegen Sie die Netzanschlubleitung so, daß niemand darüber fallen kann. Es sollte auch nichts auf der Leitung abgestellt werden.
10. Alle Hinweise und Warnungen die sich am Geräten befinden sind zu beachten.
11. Wird das Gerät über einen längeren Zeitraum nicht benutzt, sollten Sie es vom Stromnetz trennen. Somit wird im Falle einer Überspannung eine Beschädigung vermieden.
12. Durch die Lüftungsöffnungen dürfen niemals Gegenstände oder Flüssigkeiten in das Gerät gelangen. Dies könnte einen Brand bzw. elektrischen Schlag auslösen.
13. Öffnen Sie niemals das Gerät. Das Gerät darf aus Gründen der elektrischen Sicherheit nur von autorisiertem Servicepersonal geöffnet werden.
14. Wenn folgende Situationen auftreten ist das Gerät vom Stromnetz zu trennen und von einer qualifizierten Servicestelle zu überprüfen:
 - a - Netzkabel oder Netzstecker sind beschädigt.
 - b - Flüssigkeit ist in das Gerät eingedrungen.
 - c - Das Gerät war Feuchtigkeit ausgesetzt.
 - d - Wenn das Gerät nicht der Bedienungsanleitung entsprechend funktioniert oder Sie mit Hilfe dieser Anleitung keine Verbesserung erzielen.
 - e - Das Gerät ist gefallen und/oder das Gehäuse ist beschädigt.
 - f - Wenn das Gerät deutliche Anzeichen eines Defektes aufweist.
15. VORSICHT: Explosionsgefahr bei unsachgemäßen Austausch der Batterie. Ersatz nur durch denselben oder einem vom Hersteller empfohlene-mähnlichen Typ. Entsorgung gebrauchter Batterien nach Angaben des Herstellers.

Der arbeitsplatzbezogene Schalldruckpegel nach DIN 45 635 Teil 1000 beträgt 70dB(A) oder weniger.

DISCLAIMER: This set of instructions is given according to IEC704-1. Advantech disclaims all responsibility for the accuracy of any statements contained herein.

Caution!



Danger of explosion if battery is incorrectly replaced. Replace only with the same or equivalent type recommended by the manufacturer. Dispose of used batteries according to the manufacturer's instructions.

Content

Chapter 1	General Information	2
1.1	Introduction	2
1.2	Features	3
1.3	Specifications	4
1.4	Board Dimensions	6
	Figure 1.1:Board Dimensions (Component Side).....	6
	Figure 1.2:Board Dimensions (Solder Side).....	7
Chapter 2	Installation	10
2.1	Jumpers.....	10
	Table 2.1:connectors and jumpers	10
2.2	Locating jumpers and connectors.....	12
	Figure 2.1:Locating Connectors and Jumpers	12
2.3	Setting Jumpers	13
	Figure 2.2:Locating Connectors (Solder Side)	13
2.4	CPU	14
2.4.1	CMOS clear (JP1).....	15
2.4.2	PCI VIO Select (JP3).....	15
	Table 2.3:PCI VIO Select (JP3).....	15
2.4.3	COM1 and COM2 RI Input Select (JP4, JP5).....	16
	Table 2.4:COM1 and COM2 RI Input Select (JP4, JP5)..	16
	Table 2.5:COM1 and COM2 RI Input Select (JP4, JP5)..	16
2.5	SDRAM installation.....	16
2.5.1	SODIMM DRAM.....	17
2.6	Primary (2.5") IDE connector (CN12)	17
2.6.1	Connecting the hard drive.....	17
2.7	LPT1 (primary parallel port) connector	(CN14)17
2.8	Keyboard/mouse connectors (CN17)	17
2.9	Power connectors (CN15, CN18).....	18
2.9.1	Main power connector (CN15).....	18
2.9.2	ATX standby power input connector (CN18).....	18
2.10	Serial (COM1,COM2) (CN13,CN16).....	18
2.10.1	Primary(COM1:CN20/CN21,COM2:CN14/CN16).....	18
2.11	COM2 422/485 (CN6)	18
2.12	VGA interface connections	18
2.12.1	CRT display connector (CN8).....	18
2.12.2	Flat panel display connector (CN7,CN20)	18
2.12.3	Invert Power Connector (CN2).....	19
2.13	Ethernet configuration.....	19

2.13.1	Ethernet connector (CN5).....	19
2.13.2	Network boot	19
2.14	Watchdog timer configuration	19
2.14.1	Watchdog timer action (JP2).....	19
	Table 2.6: Watchdog Function J2	19
2.15	USB connector (CN26,CN27).....	20
2.16	Reset Connector (CN1)	20
	Table 2.7: Reset Connector.....	20
2.17	IR Connector (CN3).....	20
2.18	FAN Connector (CN4)	20
2.18.1	Power Switch Connector (CN19)	20
2.18.2	Negative Power Input	20
2.18.3	RTC Connector (CN22).....	21
Chapter 3	Software Configuration	24
3.1	Introduction	24
3.2	VGA display firmware configuration	24
	Figure 3.1: VGA setup screen.....	25
3.3	Connections for four standard LCDs	26
	Table 3.1: Sharp LM64183P LCD (CN35)	26
3.4	Ethernet software configuration	30
Chapter 4	Award BIOS Setup.....	32
4.1	System test and initialization.....	32
4.1.1	System configuration verification.....	32
4.2	Award BIOS setup	33
4.2.1	Entering setup	33
	Figure 4.1: Setup Program Initial Screen.....	33
4.2.2	Standard CMOS setup	33
	Figure 4.2: CMOS Setup Screen.....	34
4.2.3	BIOS features setup	35
	Figure 4.3: BIOS Features Setup Screen	35
4.2.4	Chipset features setup	36
	Figure 4.4: Chipset Features Setup Screen	36
4.2.5	Power management setup	37
	Figure 4.5: Power Management Setup Screen.....	37
4.2.6	PnP/PCI configuration setup.....	38
	Figure 4.6: PCI configuration setup screen	38
4.2.7	Integrated peripherals	39
	Figure 4.7: Integrated peripherals setup screen	39
4.2.8	Load Optimized Defaults BIOS.....	40
	Figure 4.8: Load Optimized Default BIOS screen	40
4.2.9	Set Password	40
4.2.10	Save & exit setup	41
	Figure 4.9: Save and Exit Setup Screen.....	41
4.2.11	Quit without saving.....	42

	Figure 4.10:Quit Setup Screen.....	42
Chapter 5	AGP 4X Setup.....	44
5.1	Introduction	44
5.1.1	Chipset	44
5.1.2	Display memory.....	44
5.1.3	Display types.....	44
5.1.4	Dual/Simultaneous Display	45
	Figure 5.1:Selecting Display Settings.....	45
5.2	Installation of the SVGA Driver	46
5.2.1	Installation for Windows 95	46
5.2.2	Installation for Windows 98/Me.....	50
5.2.3	Installation for Windows NT.....	55
5.2.4	Installation for Windows 2000	60
5.2.5	Installation for Windows XP	65
5.3	Further Information	71
Chapter 6	PCI Bus Ethernet Interface.....	74
6.1	Introduction	74
6.2	Installation of Ethernet Driver.....	74
6.2.1	Installation for MS-DOS and Windows 3.1.....	74
6.2.2	Installation for Windows 95	75
6.2.3	Installation for Windows 2000	78
6.2.4	Installation for Windows NT	83
6.3	Further information	87
Appendix A	Programming the Watchdog Timer	90
A.1	Programming the watchdog timer	90
Appendix B	PCM-3370F Jumper Settings	92
B.1	CN1 Reset Connector.....	93
B.2	CN2 Inverter Power Connector.....	93
B.3	CN3 IR Connector.....	94
B.4	CN4 FAN Connector.....	94
B.5	CN5 LAN Connector	95
B.6	CN6 422/485 Connector.....	96
B.7	CN7 40-Pin LCD Port (24bit).....	96
B.8	CN8 CRT Connector	97
B.9	CN9 USB Connector.....	98
B.10	CN10 20-Pin LCD Connector (36-bit).....	99
B.11	CN11 PC/104+ Connector	99
B.12	CN12 44-Pin IDE Connector	101
B.13	CN13 COM2 RS232 Connector.....	102
B.14	CN14 LPT Connector.....	102
B.15	CN15 Power Conector	103
B.16	CN16 COM1 RS232 Connector.....	104

B.17	CN17 KB/MS Connector	105
B.18	CN18 ATX Power Connector	105
B.19	CN19 Power Switch Connector	106
B.20	CN20 Negative Power Input	106
B.21	CN21 Compact Flash Slot.....	106
B.22	CN22 RTC Connector	108
B.23	JP1 COMS Charge&Discharge	108
B.24	JP2 Watchdog Timer	108
B.25	JP3 PCI VIO Select	109
B.26	JP4 COM1 RI Input Select.....	109
B.27	JP5 COM2 RI Input Select.....	110
Appendix C	System Assignments	112
C.1	System I/O ports.....	112
C.2	DMA channel assignments.....	113
C.3	Interrupt assignments	114
C.4	1st MB memory map.....	115

General Information

This chapter gives background information on the PCM-3370.

Sections include:

- Sections include:
- Introduction
- Features
- Specifications
- Board layout and dimensions

Chapter 1 General Information

1.1 Introduction

The PCM-3370 utilizes a PC/104+ form factor design that supports ULV Celeron 400/650 processors and LV Pentium III 800, 933 processors. This effective PC/104+ solution gives end users the choice of good, economical performance with the ULV Celeron series processors, or the impressive performance of the LV Pentium III series. These processor flexibility combined with all the other on-board features, explains why the PCM-3370 is the new top-of-the-line PC/104+ CPU module solution at Advantech.

The PCM-3370 is loaded with special on-board features that rival full-size systems. It has standard 10/100Base-T PCI Ethernet, 36-bit DSTN/TFT LCD panel support as well as SSD support for CompactFlash. There is PC/104 and PC/104+ socket for optional international version. The PCM-3370 also includes 1 SODIMM sockets for up to 512MB total on-board memory.

The PCM-3370 was designed using feedback and knowledge gained from our customers. It has more of the features our customers have requested. It is 100% PC compatible and is ready to handle the most challenging customer driven environments. Besides the great onboard memory flexibility and capacity, the PCM-3370 has four on-board serial ports, each with +5 V power, two USB connectors, watchdog timer and tough industrial grade construction. The Award 256 KB Flash BIOS supports Plug & Play, Boot from Ethernet, Boot from CD-ROM, Boot from Zip drive, Wake-on-Lan, Modem and LCD backlight turnoff. All these features make the PCM-3370 a very "system integrator friendly" solution, perfect for handling medical, DVR, Industrial automation and transportation applications in the harshest unmanned environments.

1.2 Features

- All-in-one design simplifies system integration and increases system stability
- Supports ULV Celeron 400/650 and LV Pentium III 800/933 processors.
- Supports on-board features such as 1 x RS-232&1 x RS-232/422/485 with power and 2 x USB interfaces for external peripherals.
- 100/10Base-T with RJ-45 connection for the most demanding networking environment
- Supports PC/104 and PC/104+ for optional PC/104 and PC/104+ peripheral module
- Supports wake-on LAN, modem
- Special industrial features not found on conventional motherboards include watchdog timer and SSD
- Standardized layout conforms to PC/104 and PC/104+ format for easy installation within standard sized chassis
- Supports up to 36-bit DSTN/TFT high resolution LCDs
- Advanced CPU switching power technology for stable and low heat CPU voltage power conversion
- Supports CompactFlash® card

1.3 Specifications

Standard SBC functions

- **CPU:** On-board ULV Intel Celeron 400/650 (Fanless) / LV Pentium III 800/933 processor
- **BIOS:** Award 256 KB Flash memory
- **Chipset:** VIA 8606/TwisterT, VT82C686B
- **System memory:** One SODIMM sockets accept 32 MB ~ 512MB SDRAM
- **Enhanced IDE interface:** Supports up to two EIDE devices. BIOS auto-detect, PIO Mode 3 or Mode 4, UDMA/33 transfer
- **Serial ports:** Two serial RS-232 ports, COM1, 4: RS-232, COM2: RS-232/422/485
- **Parallel port:** One parallel ports, supports SPP/EPP/ECP mode
- **Infrared port:** Shared with COM2. Transfer rates up to 1.15 Mbps
- **Keyboard/mouse connector:** Supports standard PS/2 keyboard and a PS/2 mouse
- **Power management:** Supports power saving modes including Normal/Standby/Suspend modes. APM 1.1 compliant
- **Watchdog timer:** 1.6 sec. intervals generate system reset or IRQ11
- **USB:** Two universal serial bus ports (USB1.1)

Solid state disk

- Supports one 50-pin socket for CompactFlash™ card

VGA/LCD interface

- **Chipset:** VIA VT8606/TwisterT, optimized Shared Memory Architecture, support 8/16/32 MB frame buffer using system memory.
- **Interface:** 4X AGP interface
- **Display mode:** Flat panel displays up to 600 x 480 @ 18 bpp 800 x 600 @ 18 bpp, 1024 x 768 @ 18 bpp, CRT monitors up to 800 x 600 @ 24 bpp, 1024 x 768 @ 16 bpp, 1280 x 1024@16 bpp

Ethernet interface

- **Chipset:** Realtek RTL8139D
- **Ethernet interface:** PCI 10/100 Mbps Ethernet. IEEE 802.3 U protocol compatible

- Connection: On-board RJ-45 connector
- Built-in boot ROM

Mechanical and environmental

- Max. power requirements: 5V@2.4A for Intel Celeron ULV 400 @ 128M
- Operating temperature: 0 ~ 60° C (32 ~ 140° F)
- Dimensions (L x W): 96 mm x 115 mm (3.77" x 4.05")
- Weight: 0.2Kg (0.48lb)

1.4 Board Dimensions

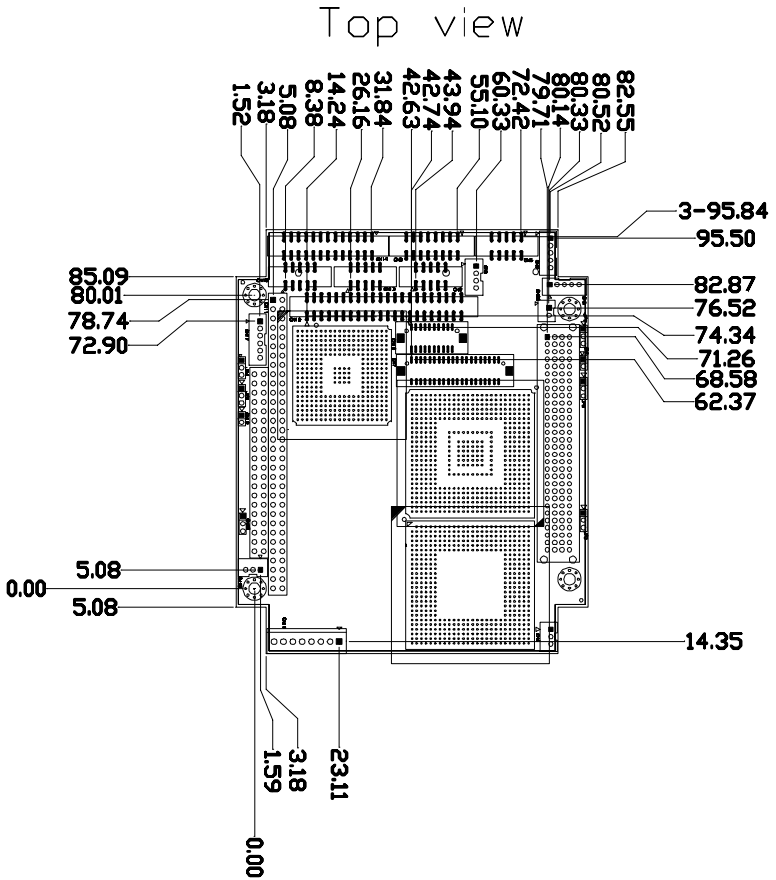
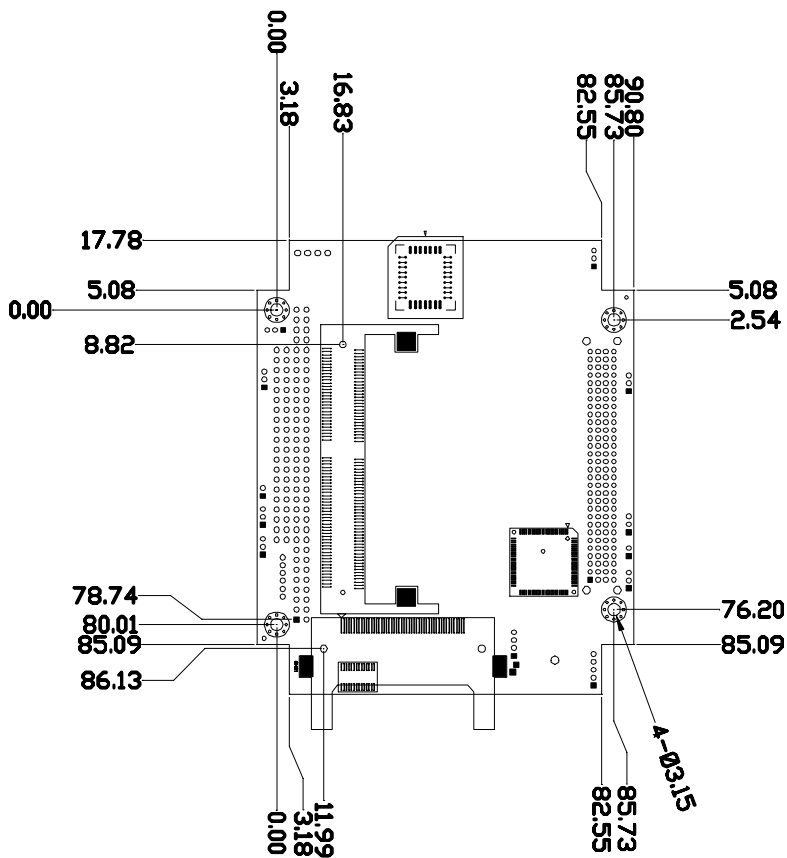

Figure 1.1: Board Dimensions (Component Side)



Bottom view

Figure 1.2: Board Dimensions (Solder Side)

Installation

This chapter explains how to set up the PCM-3370 hardware, including instructions on setting jumpers and connecting peripherals, switches and indicators. Be sure to read all the safety precautions before you begin the installation procedure.

Chapter 2 Installation

2.1 Jumpers

The PCM-3370 has a number of jumpers that allow you to configure your system to suit your application. The table below lists the function of each of the board's connectors and jumpers

Table 2.1: connectors and jumpers

Label	Function
CN1	Reset connector
CN2	Invert power connector
CN3	IR connector
CN4	FAN connector
CN5	LAN hard disk connector
CN6	422/485 connector
CN7	40-pin LCD port (24bit)
CN8	CRT
CN9	USB connector
CN10	20-Pin LCD connector (36-bit)
CN11	PC/104+ connector
CN12	44-pin IDE connector
CN13	COM2 RS232 connector
CN14	LPT connector
CN15	Power Connector
CN16	COM1 RS232 connector
CN17	KB/MS connector
CN18	ATX power connector
CN19	Power Switch connector
CN20	Negative Power input
CN21	Compact Flash Slot
CN22	RTC connector
JP1	CMOS Charge&Discharge

JP2	Watchdog Timer
JP3	PCI VIO SELECT
JP4	COM1 RI Input Select
JP5	COM2 RI Input Select

2.2 Locating jumpers and connectors

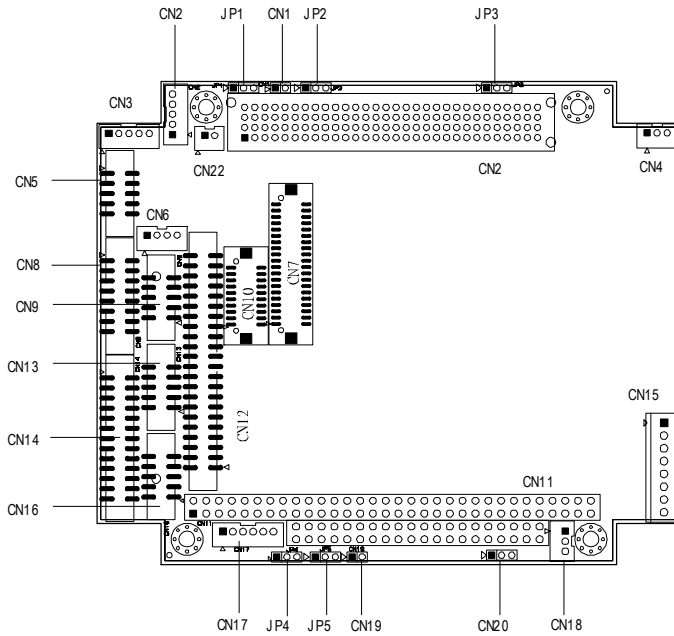

Figure 2.1: Locating Connectors and Jumpers

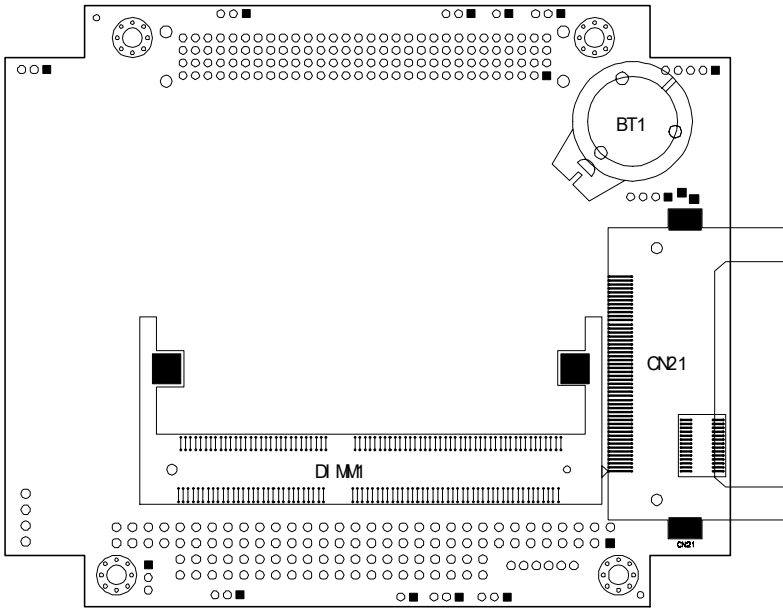
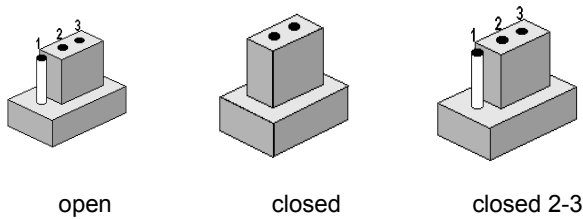

Figure 2.2: Locating Connectors (Solder Side)

2.3 Setting Jumpers

You configure your board to match the needs of your application by setting jumpers. A jumper is the simplest kind of electric switch. It consists of two metal pins and a small metal clip (often protected by a plastic cover) that slides over the pins to connect them. To close a jumper you connect the pins with the clip. To open a jumper you remove the clip. Sometimes a jumper will have three pins, labeled 1, 2, and 3. In this case you would connect either pins 1 and 2 or 2 and 3.



The jumper settings are schematically depicted in this manual as follows:

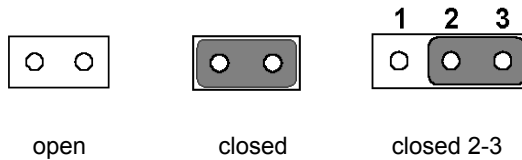

A pair of needle-nose pliers may be helpful when working with jumpers. If you have any doubts about the best hardware configuration for your application, contact your local distributor or sales representative before you make any changes.

Generally, you simply need a standard cable to make most connections.

2.4 CPU

There are 4 CPU can be on-board. ULV Intel Celeron 400/650 and LV Intel Pentium III 800/933.

Warning! *Always disconnect the power cord from your chassis when you are working on it. Do not make connections while the power is on as sensitive electronic components can be damaged by the sudden rush of power. Only experienced electronics personnel should open the PC chassis*



Caution!  Always ground yourself to remove any static charge before touching the PC board. Modern electronic devices are very sensitive to static electric charges. Use a grounding wrist strap at all times. Place all electronic components on a static-dissipative surface or in a static-shielded bag when they are not in the chassis.

Warning! To avoid damaging the computer, always turn off the power supply before setting “Clear CMOS.” Set the jumper back to “3V Battery On” before turning on the power supply.

2.4.1 CMOS clear (JP1)

Table 2.2: JP2 Watchdog Timer

Pin	Function
1-2	Reset *
2-3	IRQ11

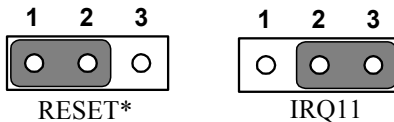

2.4.2 PCI VIO Select (JP3)

It is a PCI I/O voltage selection. It has VCC(+5V), VCC3(+3.3V) and NULL.

Table 2.3: PCI VIO Select (JP3)

JP3	PCI VIO SELECT
Pin	Function
1-2	VCC
2-3	VCC3
Default	NULL *

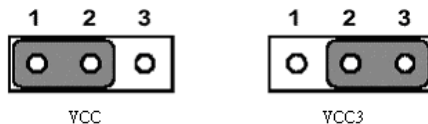

2.4.3 COM1 and COM2 RI Input Select (JP4, JP5)

There is Ring input select jumper at COM1 and COM2.

Table 2.4: COM1 and COM2 RI Input Select (JP4, JP5)

JP4	COM1 RI Input Select
Pin	Function
1-2	RI *
2-3	VCC

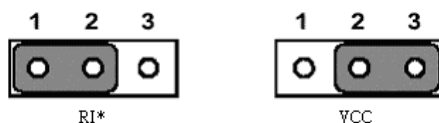
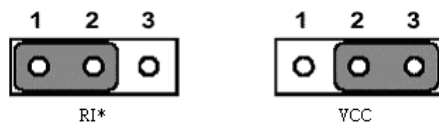

Table 2.5: COM1 and COM2 RI Input Select (JP4, JP5)

JP5	COM2 RI Input Select
Pin	Function
1-2	RI *
2-3	VCC



2.5 SDRAM installation

There are one on-board 144-pin SODIMM socket.

2.5.1 SODIMM DRAM

You can install one DiMM (up to 512 MB).

Caution! *When installing SODIMM, make sure the module is oriented properly. Do not use excess force during installation.*



2.6 Primary (2.5") IDE connector (CN12)

The 44-pin IDE connector supports up to two 44-pin IDE interface devices, including CD-ROM drives, tape-backup drives, HDDs, etc. When connecting, make sure pin 1 of the connector is matched with pin of the device's connector.

The built-in Enhanced IDE (Integrated Device Electronics) controller supports up to two IDE devices, including CD-ROM drives, tape backup drives, a large hard disk drive and other IDE devices. It also supports faster data transfer rates and allows IDE hard disk drives with capacities in excess of 528 MB.

2.6.1 Connecting the hard drive

Connecting drives is done in a daisy-chain fashion. Wire number 1 on the cable is red or blue, while the other wires are gray.

Unlike floppy drives, IDE hard drives can connect to either end of the cable. If you install two drives, you will need to set one as the master and one as the slave by using jumpers on the drives. If you install just one drive, set it as the master.

2.7 LPT1 (primary parallel port) connector (CN14)

The primary parallel printer port is located at the rear edge of the board, and has a 26pin box header connector. This printer port is typically used to connect a printer via an adapter cable. LPT1's IRQ setting is defined as IRQ7. You can select Normal/EPP/ECP for LPT1, and enable/disable it in BIOS (see Chapter 4).

2.8 Keyboard/mouse connectors (CN17)

There is an internal 6 pin KB/Mouse connector (CN17). It need to use Y-type connector to connect Keyboard and mouse.

2.9 Power connectors (CN15, CN18)

2.9.1 Main power connector (CN15)

The power connection is a 8-pin connector requiring +5 V and +12 V power. It needs a cable (1703080104 for AT or 1703200380 for ATX) to connect AT/ATX power supply.

2.9.2 ATX standby power input connector (CN18)

The power connection is a 3-pin connector requiring +5 V standby

2.10 Serial (COM1,COM2) (CN13,CN16)

The PCM-3370 has a total of two on-board RS-232 serial ports, COM1 and COM2. They are COM1(RS-232) and COM2 (RS-232/422/485). Both serial ports have +5 V power capabilities on both pin #1.

2.10.1 Primary(COM1:CN20/CN21,COM2:CN14/CN16)

Each primary serial port has internal 10-pin header giving the user the ability to adapt the board to many different systems. IRQ for COM1 and COM2 is fixed with COM1 on IRQ4 and COM2 on IRQ3. COM1 and COM2 can be enabled or disabled via BIOS (see Chapter 4).

2.11 COM2 422/485 (CN6)

There is a 4-pin boxheader connector for COM2 RS-422/485 connection purpose.

2.12 VGA interface connections

The PCM-3370 's AGP 4X interface can drive conventional CRT displays and is capable of driving a wide range of flat panel displays, including electroluminescent (EL), gas plasma, passive LCD and active LCD displays. The board has two connectors to support these displays, one for standard CRT VGA monitors and one for flat panel displays.

2.12.1 CRT display connector (CN8)

CN8 is a standard 16-pin (2x8) box header connector commonly used for the CRT VGA monitor only. Pin assignments appear in the appendix.

2.12.2 Flat panel display connector (CN7,CN20)

CN7 is 40-pin Hirose connector and CN10 is 20-pin Hirose connector. It can connect to a 36-bit TFT LCD panel. Pin assignments appear in the appendix. (For more information on LCD connection information between CN7 and CN10 and an LCD, refer to Chapter 3.)

2.12.3 Invert Power Connector (CN2)

The PCM-33701F inverter power connector is a 5-pin boxheader.

2.13 Ethernet configuration

The PCM-3370 is equipped with a high performance 32-bit PCI-bus Ethernet interface which is fully compliant with IEEE 802.3 u 10/100Mbps CSMA/CD standards. It is supported by all major network operating systems.

The medium type can be configured via the RSET8139.EXE program included on the utility disk (see Chapter 3 for detailed information).

2.13.1 Ethernet connector (CN5)

100/10Base-T connects to the PCM-3370 via an internal 10pin box header and use the cable link of RJ-45 standard jack.

2.13.2 Network boot

The Network Boot feature can be utilized by incorporating the Boot ROM image files for the appropriate network operating system. The Boot ROM BIOS files are on the included utility disk.

2.14 Watchdog timer configuration

An onboard watchdog timer reduces the chance of disruptions which EMP (electro-magnetic pulse) interference can cause. This is an invaluable protective device for standalone or unmanned applications. Setup involves one jumper and running the control software (refer to Appendix A).

2.14.1 Watchdog timer action (JP2)

When the watchdog timer activates (CPU processing has come to a halt), it can reset the system or generate an interrupt on IRQ11. This can be set via setting J2 as shown below:

Table 2.6: Watchdog Function J2

Closed pins	Result
1-2	Reset*

Table 2.6: Watchdog Function J2

2-3	IRQ11
-----	-------

2.15 USB connector (CN26,CN27)

The PCM-3370 board provides two USB (Universal Serial Bus) interfaces which support plug and play and hot attach/detach for up to 127 external devices. The USB interfaces comply with USB specification Rev. 1.1 and are fuse protected.

The USB interfaces are accessed through 10-pin (5x2) flat-cable connectors, CN9. You will need an adapter cable if you use a standard USB connector. The adapter cable has a 5-pin connector on one end and a USB connector on the other.

The USB interfaces can be disabled in the system BIOS setup.

2.16 Reset Connector (CN1)

Table 2.7: Reset Connector

Pin	Pin name
1	Signal
2	Gnd

2.17 IR Connector (CN3)

PCM-3370F's IR is a 5pin boxheader. There is more detail pin assignment at Appendix.

2.18 FAN Connector (CN4)

The PCM-3370F's FAN connector has speed detect and +5V power input. It is a 3 pin connector for FAN.

2.18.1 Power Switch Connector (CN19)

There is a PCM-3370F 2-pin power switch at CN19.

2.18.2 Negative Power Input

PCM-3370F can have -5V and -12V negative power input from outside power supply then it can drive stacking module -5V/-12V from PC/104 socket. It is a 3-pin box header.

2.18.3 RTC Connector (CN22)

PCM-3370F has a 2-pin boxheader real time clock connector.

Software Configuration

This chapter details the software configuration information. It shows you how to configure the card to match your application requirements. Award System BIOS will be covered in Chapter 4.

Sections include:

- Introduction
- VGA display software configuration
- LCD display configuration
- Connections for four standard LCDs
- Ethernet interface configuration

Chapter 3 Software Configuration

3.1 Introduction

The PCM-3370 system BIOS and custom drivers are located in a 256 KB, 32-pin (JEDEC spec.) Flash ROM device, designated U23. A single Flash chip holds the system BIOS, VGA BIOS, and network Boot ROM image. The display can be configured via software. This method minimizes the number of chips and eases configuration. You can change the display BIOS simply by reprogramming the Flash chip.

3.2 VGA display firmware configuration

The PCM-3370's on-board VGA interface supports a wide range of popular LCD, EL, gas plasma flat panel displays and traditional analog CRT monitors. The optimized shared memory architecture supports an 8/16/32 MB frame buffer using system memory to provide resolutions of 1280 x 1024 @ 16 bpp, the interface can drive CRT displays with resolutions up to 1024 x 768 @ 16 bpp and 800 x 600 @ 16 bpp.

The VGA interface is configured completely via the software utility, so you do not have to set any jumpers. Configure the VGA display as follows:

1. Apply power to the PCM-3370 with a color TFT display attached. This is the default setting for the PCM-3370. Ensure that the AWD-FLASH.EXE and *.BIN files are located in the working drive.

NOTE: *Ensure that you do not run AWDFLASH.EXE while your system is operating in EMM386 mode.*

2. At the prompt, type AWDFLASH.EXE and press <Enter>. The VGA configuration program will then display the following:

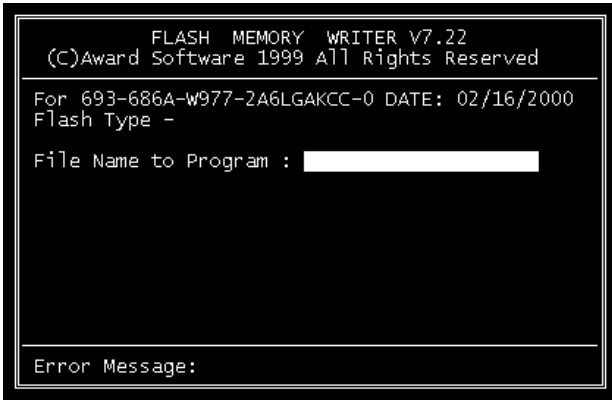

Figure 3.1: VGA setup screen

3. At the prompt, enter the new BIN file which supports your display. When you are sure that you have entered the file name correctly press <Enter>.
4. The screen will ask *Do you want to save BIOS?*. If you change your mind or have made a mistake, press N to abort and end the setup procedure. Press Y if you wish to save the existing configuration before changing it. Then type the name under which you want to save the current configuration.
5. The prompt will then ask *Are you sure to program?*. Press Y if you want the new file to be written into the BIOS. Press N to exit the program.

The new VGA configuration will then write to the ROM BIOS chip. This configuration will remain the same until you run the AWDFLASH.EXE program and change the settings.

3.3 Connections for four standard LCDs

Connections to Sharp LM64183P (640 x 480 DSTN MONO LCD)

Table 3.1: Sharp LM64183P LCD (CN35)

LM64183P		PCM-3370 (CN35)	
Pin	Name	Pin	Name
CN1-1	S	36	FLM
CN1-2	CP1	38	LP
CN1-3	CP2	35	SHFCLK
CN1-4	DISP	5	+5 V
CN1-5	VDD	6	+5 V
CN1-6	VSS	3	GND
CN1-7	VEE	-	-17 V (external power)
CN1-8	DU0	12	P3
CN1-9	DU1	11	P2
CN1-10	DU2	10	P1
CN1-11	DU3	9	P0
CN1-12	DL0	16	P7
CN1-13	DL1	15	P6
CN1-14	DL2	14	P5
CN1-15	DL3	13	P4

* LM64183P requires -17 V for VEE

Connections to PLANAR EL640.480-AM1 (640 x 480 EL LCD)

Table 3.2: PCM-3370 connection for PLANAR EL LCD (CN35)

PLANAR 640.480-AM1		PCM-3370 (CN35)	
Pin	Name	Pin	Name
1	UD1	11	P2
2	UDO	12	P3
3	UD3	9	P0
4	UD2	10	P1
5	LD1	15	P6
6	LD0	16	P7

Table 3.2: PCM-3370 connection for PLANAR EL LCD (CN35)

7	LD3	13	P4
8	LD2	14	P5
9	CP2	35	SHFCLK
10	GND	33	GND
11	CP1	38	LP
12	GND	33	GND
13	S	36	FLM
14	GND	34	GND
15	GND	3	GND
16	GND	4	GND
17	VL	5	VCC
18	VL	6	VCC
19	VH	1	+12 V
20	VH	2	+12 V

Connections to Toshiba LTM10C209A (640 x 480 TFT color LCD)

Table 3.3: Toshiba LTM10C209A LCD (CN35)

LTM10C209A		PCM-3370 (CN35)	
Pin	Name	Pin	Name
1	GND	3	GND
2	CLK	35	SHFCLK
3	GND	4	GND
4	R0	27	P18
5	R1	28	P19
6	R2	29	P20
7	GND	8	GND
8	R3	30	P21
9	R4	31	P22
10	R5	32	P23
11	GND	33	GND
12	G0	19	P10

Table 3.3: Toshiba LTM10C209A LCD (CN35)

13	G1	20	P11
14	G2	21	P12
15	GND	33	GND
16	G3	22	P13
17	G4	23	P14
18	G5	24	P15
19	GND	34	GND
20	ENAB	37	M
21	GND	34	GND
22	B0	11	P2
23	B1	12	P3
24	B2	13	P4
25	GND	39	GND
26	B3	14	P5
27	B4	15	P6
28	B5	16	P7
29	GND	39	GND
30	VDD	5	+5 V
31	VDD	6	+5 V

Connections to Kyocera KCB6446BSTT-X5 (640 x 480 DSTN color LCD)

Table 3.4: PCM-3370 connection for Kyocera KCB6446BSTT-X5 LCD (CN35)

KCB6446BSTT-X5		PCM-3370 (CN35)	
Pin	Name	Pin	Name
CN1-1	FRM	36	FLM
CN1-2	DF	-	-
CN1-3	DISP	40	ENABKL
CN1-4	LOAD	38	LP
CN1-5	VSS	33	GND
CN1-6	CP	35	SHFCLK

Table 3.4: PCM-3370 connection for Kyocera KCB6446BSTT-X5 LCD (CN35)

CN1-7	VSS	34	GND
CN1-8	HD0	20	P11
CN1-9	HD1	19	P10
CN1-10	HD2	18	P9
CN1-11	HD3	17	P8
CN1-12	HD4	12	P3
CN1-13	HD5	11	P2
CN1-14	HD6	10	P1
CN1-15	HD7	9	P0
CN2-1	LD0	24	P15
CN2-2	LD1	23	P14
CN2-3	LD2	22	P13
CN2-4	LD3	21	P12
CN2-5	LD4	16	P7
CN2-6	LD5	15	P6
CN2-7	LD6	14	P5
CN2-8	LD7	13	P4
CN2-9	VDD	5	VCC
CN2-10	VSS	3	GND
CN2-11	NC	-	-
CN2-12	NC	-	-
CN2-13	NC	-	-
CN2-14	VCONT	*7	*VEESAFE

3.4 Ethernet software configuration

The PCM-3370's on-board Ethernet interface supports all major network operating systems. To configure the medium type, to view the current configuration, or to run diagnostics, do the following:

1. Power the PCM-3370 on. Ensure that the RSET8139.EXE file is located in the working drive.
2. At the prompt type RSET8139.EXE and press <Enter>. The Ethernet configuration program will then be displayed.
3. This simple screen shows all the available options for the Ethernet interface. Just highlight the option you wish to change by using the Up and Down keys. To change a selected item, press <Enter>, and a screen will appear with the available options. Highlight your option and press <Enter>. Each highlighted option has a helpful message guide displayed at the bottom of the screen for additional information.
4. After you have made your selections and you are sure that this is the configuration you want, press ESC. A prompt will appear asking if you want to save the configuration. Press Y if you want to save.

The Ethernet Setup Menu also offers three very useful diagnostic functions. These are:

1. Run EEPROM Test.
2. Run Diagnostics on Board.
3. Run Diagnostics on Network.

Each option has its own display screen which shows the format and result of any diagnostic tests undertaken.

CHAPTER 4

Award BIOS Setup

This chapter describes how to set BIOS configuration data.

Chapter 4 Award BIOS Setup

4.1 System test and initialization

These routines test and initialize board hardware. If the routines encounter an error during the tests, you will either hear a few short beeps or see an error message on the screen. There are two kinds of errors: fatal and non-fatal. The system can usually continue the boot up sequence with non-fatal errors. Non-fatal error messages usually appear on the screen along with the following instructions:

press <F1> to RESUME

Write down the message and press the F1 key to continue the bootup sequence.

4.1.1 System configuration verification

These routines check the current system configuration against the values stored in the card's CMOS memory. If they do not match, the program outputs an error message. You will then need to run the BIOS setup program to set the configuration information in memory.

There are three situations in which you will need to change the CMOS settings:

1. You are starting your system for the first time.
2. You have changed the hardware attached to your system.
3. The CMOS memory has lost power and the configuration information has been erased.

The PCM-3370's CMOS memory has an integral lithium battery backup. The battery backup should last ten years in normal service, but when it finally runs down, you will need to replace the complete unit.

4.2 Award BIOS setup

Award's BIOS ROM has a built-in Setup program that allows users to modify the basic system configuration. This type of information is stored in battery-backed CMOS RAM so that it retains the Setup information when the power is turned off.

4.2.1 Entering setup

Power on the computer and press immediately. This will allow you to enter Setup.

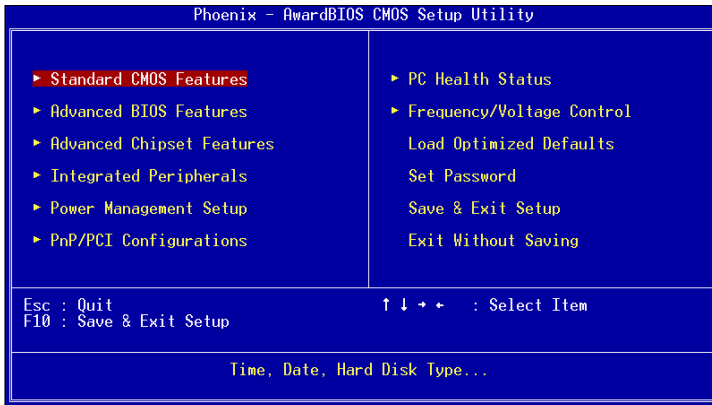

Figure 4.1: Setup Program Initial Screen

4.2.2 Standard CMOS setup

When you choose the Standard CMOS Setup option from the Initial Setup Screen menu, the screen shown below is displayed. This standard Setup Menu allows users to configure system components such as date, time, hard disk drive, display, and memory. Once a field is highlighted,

online help information is displayed in the left bottom of the Menu screen.

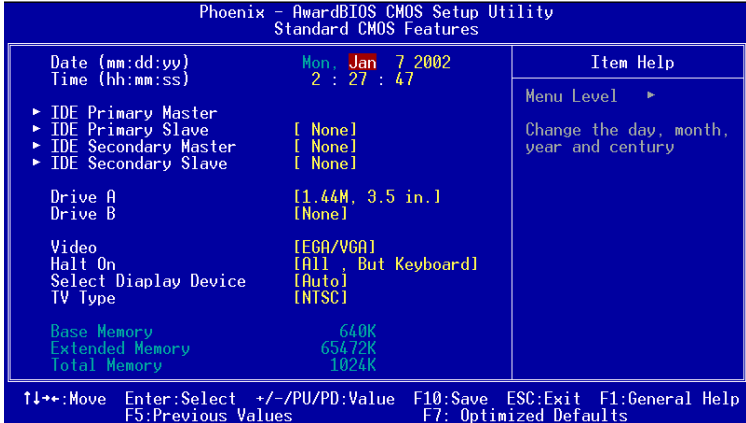

Figure 4.2: CMOS Setup Screen

4.2.3 BIOS features setup

By choosing the BIOS FEATURES Setup option from the Initial Setup Screen menu, the screen below is displayed. This sample screen contains the manufacturer's default values for the PCM-3370.

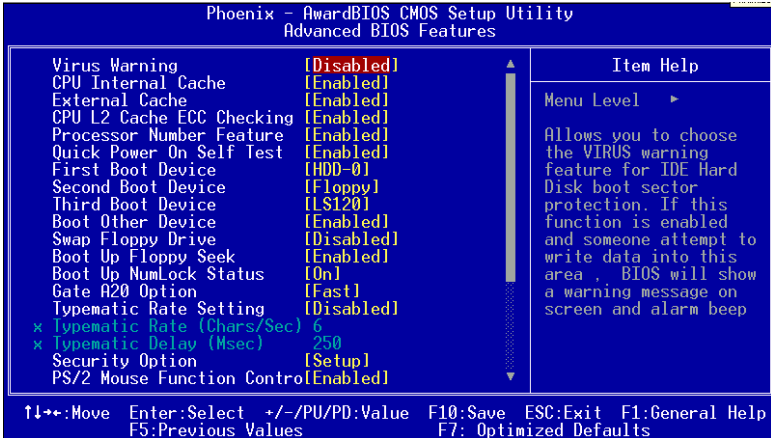

Figure 4.3: BIOS Features Setup Screen

4.2.4 Chipset features setup

By choosing the CHIPSET FEATURES Setup option from the Initial Setup Screen menu, the screen below is displayed. This sample screen contains the manufacturer's default values for the PCM-3370.

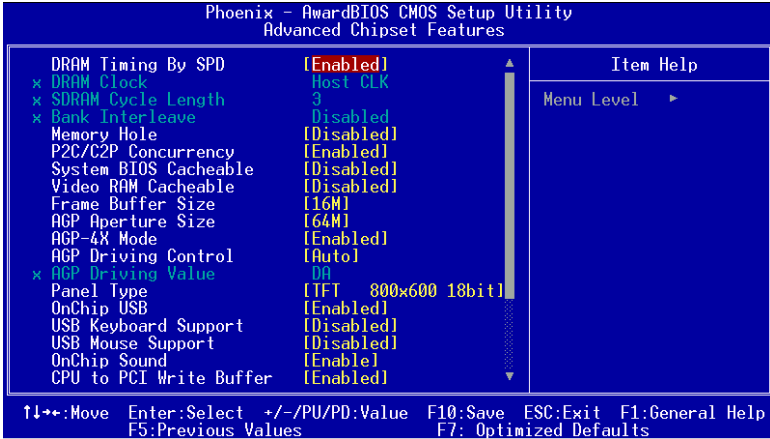

Figure 4.4: ChipsetFeatures Setup Screen

4.2.5 Power management setup

By choosing the POWER MANAGEMENT Setup option from the Initial Setup Screen menu, the screen below is displayed. This sample screen contains the manufacturer's default values for the PCM-3370.

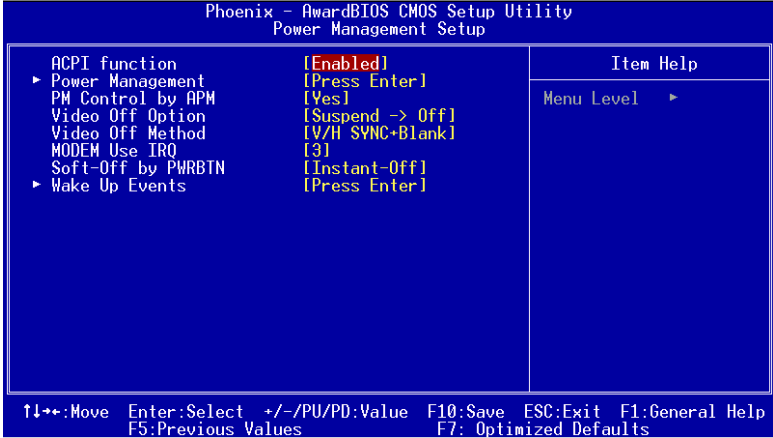

Figure 4.5: Power Management Setup Screen

4.2.6 PnP/PCI configuration setup

By choosing the PnP/PCI CONFIGURATION option from the Initial Setup Screen menu, the screen below is displayed. This sample screen contains the manufacturer's default values for the PCM-3370.

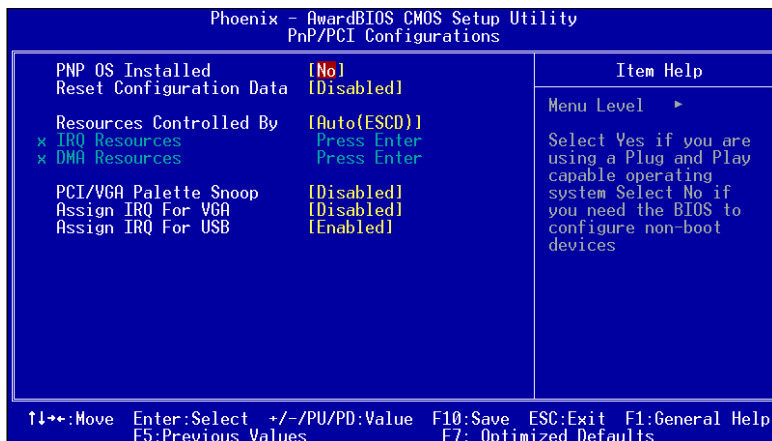

Figure 4.6: PCI configuration setup screen

4.2.7 Integrated peripherals

By choosing the INTEGRATED PERIPHERALS option from the Initial Setup Screen menu, the screen below is displayed. This sample screen contains the manufacturer's default values for the PCM-3370.

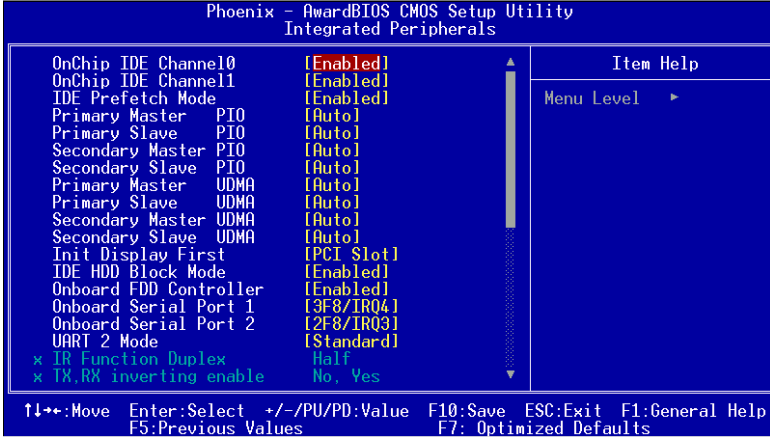

Figure 4.7: Integrated peripherals setup screen

4.2.8 Load Optimized Defaults BIOS

LOAD OPTIMIZED DEFAULTS loads the default optimized system values directly from ROM. If the stored record created by the Setup program becomes corrupted (and therefore unusable), these defaults will load automatically when you turn the PCM-3370 on.

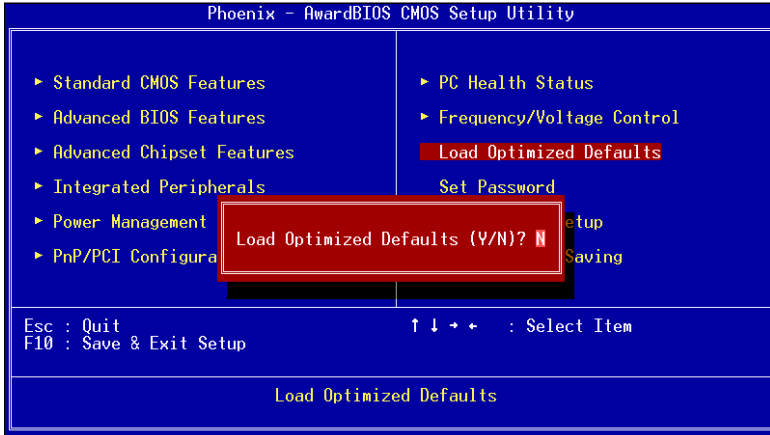

Figure 4.8: Load Optimized Default BIOS screen

4.2.9 Set Password

To change the password, choose the SET PASSWORD option from the Setup main menu and press <Enter>.

1. If the CMOS is bad or this option has never been used, there is default password which is stored in the ROM. The screen will display the following messages:

Enter Password

Press <Enter>.

2. If the CMOS is good or this option has been used to change the default password, the user is asked for the password stored in the CMOS. The screen will display the following message:

Confirm Password

Enter the current password and press <Enter>.

3. After pressing <Enter> (ROM password) or the current password (user-defined), you can change the password stored in the CMOS. The password can be at most 8 characters long.

Remember - to enable this feature, you must first select either Setup or System in the BIOS FEATURES SETUP.

4.2.10 Save & exit setup

If you select this option and press <Enter>, the values entered in the setup utilities will be recorded in the chipset's CMOS memory. The microprocessor will check this every time you turn your system on and compare this to what it finds as it checks the system. This record is required for the system to operate.

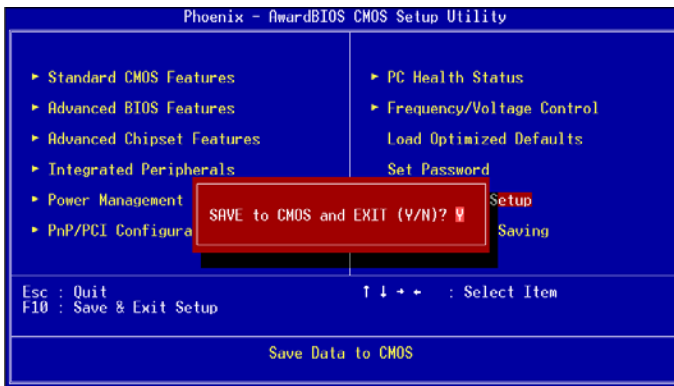

Figure 4.9: Save and Exit Setup Screen

4.2.11 Quit without saving

Selecting this option and pressing <Enter> lets you Quit the Setup program without recording any new values or changing old ones.

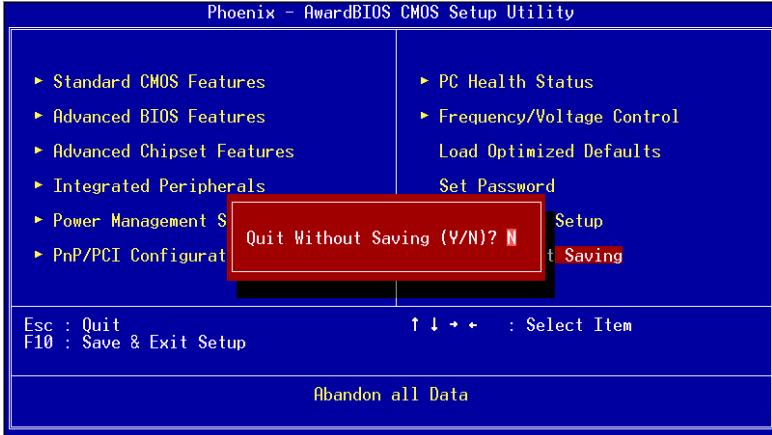

Figure 4.10: Quit Setup Screen

AGP 4X Setup

The PCM-3370 features an onboard AGP 4X flat panel/VGA interface. This chapter provides instructions for installing and operating the software drivers on the included display driver diskette.

Chapter 5 AGP 4X Setup

5.1 Introduction

The PCM-3370 has an onboard AGP flat panel/VGA interface. The specifications and features are described as follows:

5.1.1 Chipset

The PCM-3370 uses a VIA Twister 8606T chipset from VIA Technology Inc. for its AGP/SVGA controller. It supports many popular LCD, and LVDS LCD displays and conventional analog CRT monitors. The VIA8606T VGA BIOS supports color TFT and DSTN LCD flat panel displays. In addition, it also supports interlaced and non-interlaced analog monitors (color and monochrome VGA) in high-resolution modes while maintaining complete IBM VGA compatibility. Digital monitors (i.e. MDA, CGA, and EGA) are NOT supported. Multiple frequency (multisync) monitors are handled as if they were analog monitors.

5.1.2 Display memory

The Twister chip can support 8/16/32MB frame buffer shared with system memory; the VGA controller can drive CRT displays or color panel displays with resolutions up to 1280 x 1024 at 16 M colors.

5.1.3 Display types

CRT and panel displays can be used simultaneously. The PCM-3370 can be set in one of three configurations: on a CRT, on a flat panel display, or on both simultaneously. The system is initially set to simultaneous display mode. If you want to enable the CRT display only or the flat panel display only, please contact VIA Technology Inc., or our sales representative for detailed information.

5.1.4 Dual/Simultaneous Display

The PCM-3370 uses a VIA Twister VT8606T LCD controller that is capable of providing simultaneous dual view display of the same content on a flat panel and CRT.

To set up dual view (simultaneous mode) under Windows 9x, Windows ME, Windows NT/2000/XP, follow these steps:

- Step 1. Open the Control panel, and select “Display”, “Settings”.
- Step 2. Select " CRT+LCD " or " CRT+TV " for dual view
- Step 3. Click “OK”.

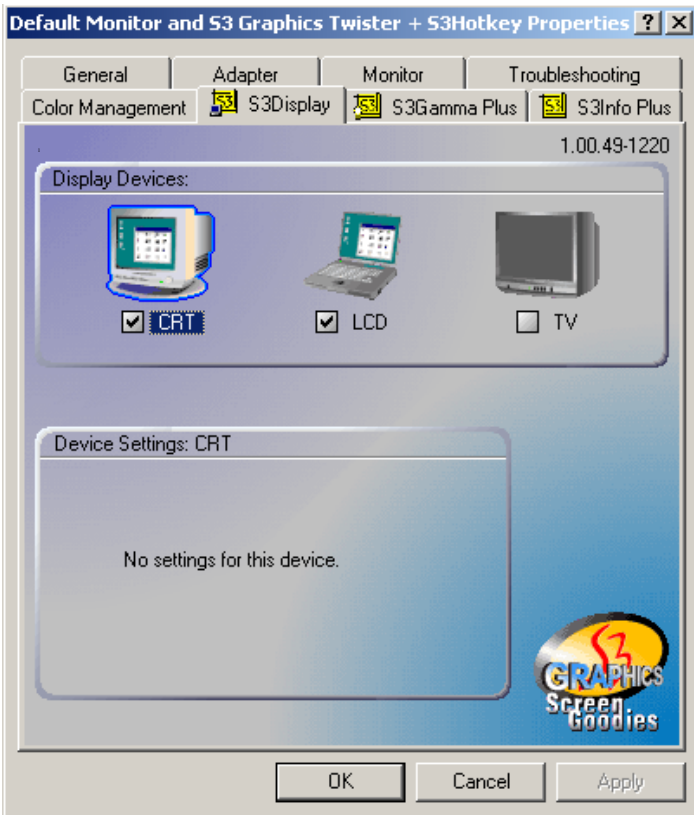

Figure 5.1: Selecting Display Settings

5.2 Installation of the SVGA Driver

Complete the following steps to install the SVGA driver. Follow the procedures in the flow chart that apply to the operating system that you are using within your PCM-3370.

- Notes:**
1. *The windows illustrations in this chapter are intended as examples only. Please follow the listed steps, and pay attention to the instructions which appear on your screen.*
 2. *For convenience, the CD-ROM drive is designated as "D" throughout this chapter.*

5.2.1 Installation for Windows 95

1. Select "Start", "Settings", "Control Panel", "Display", "Settings", and "Advanced Properties".

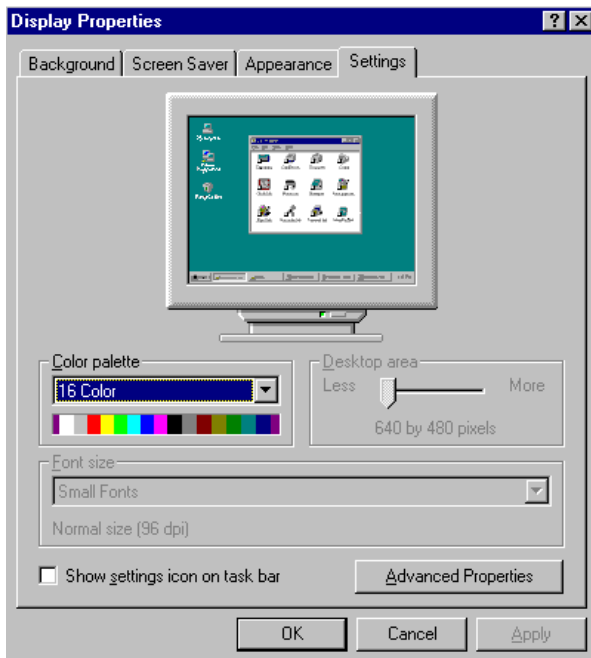

2. Choose the "Adapter" tab, then press the "Change..." button.

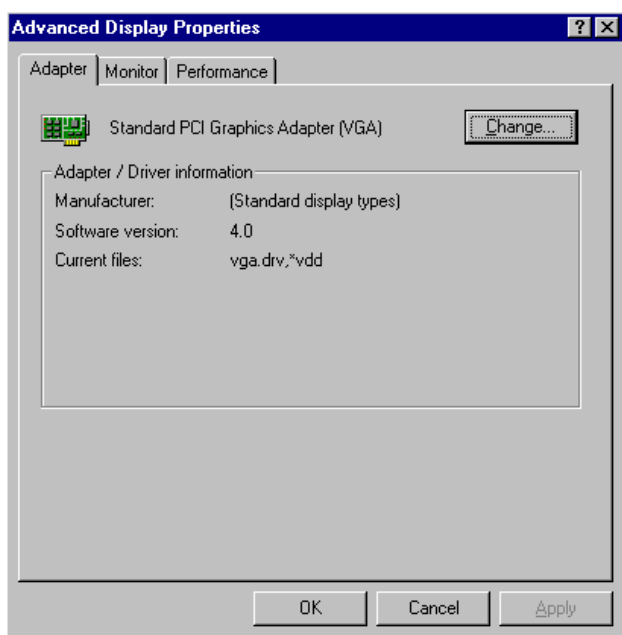

3. Press the "Have Disk" button.

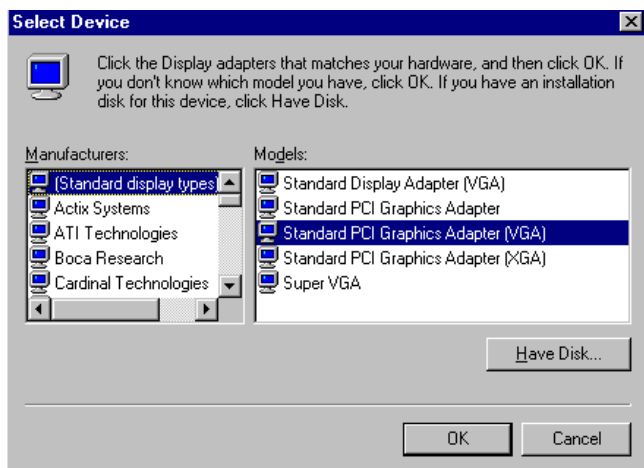

4. Type in the path:
D:\vga\VT8606\Win9x_Me



5. Select the highlighted item, and click the "OK" button.

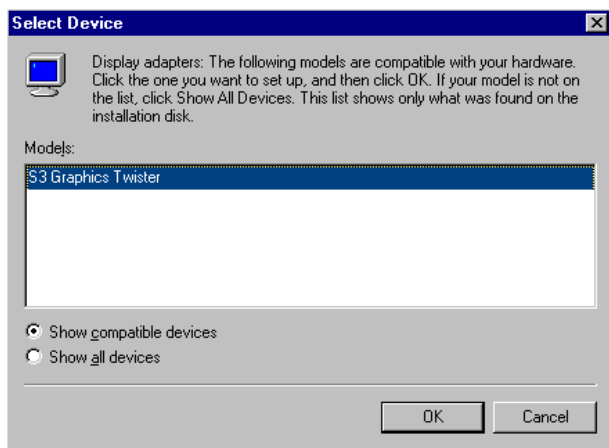

6. "S3 GraphicsTwister" appears under the adapter tab. Click the "Apply" button, then the "OK" button.

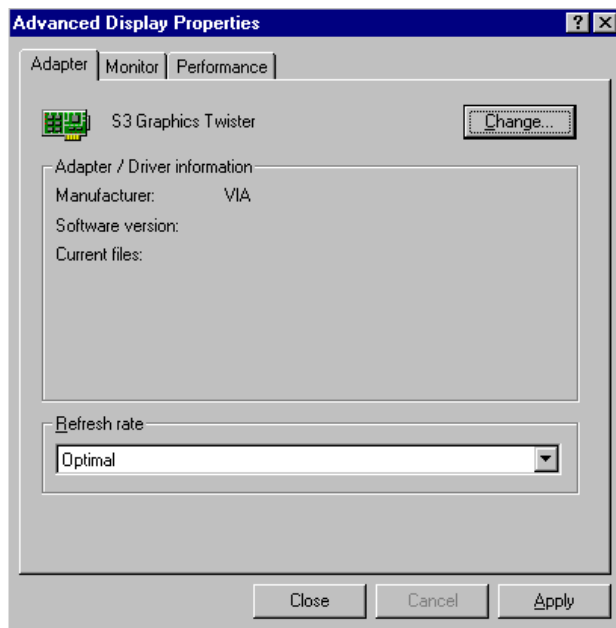

7. Press "Yes" to reboot.

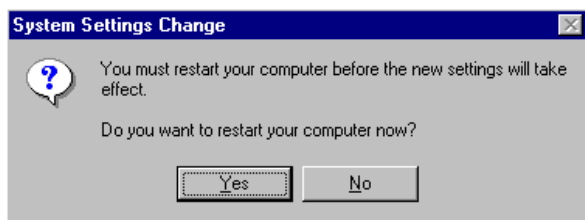

5.2.2 Installation for Windows 98/Me

1. Select "Start", "Settings", "Control Panel", "Display", and "Settings," then press the "Advanced..." button.

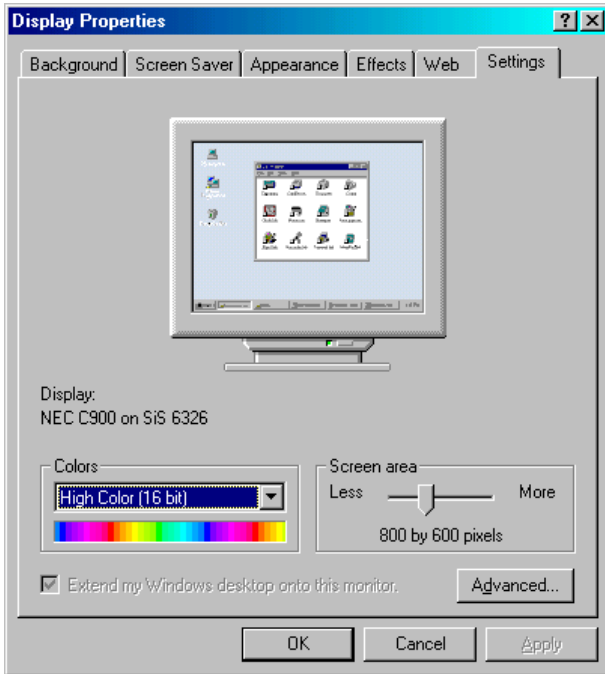

2. Select “Adapter,” then “Change.”

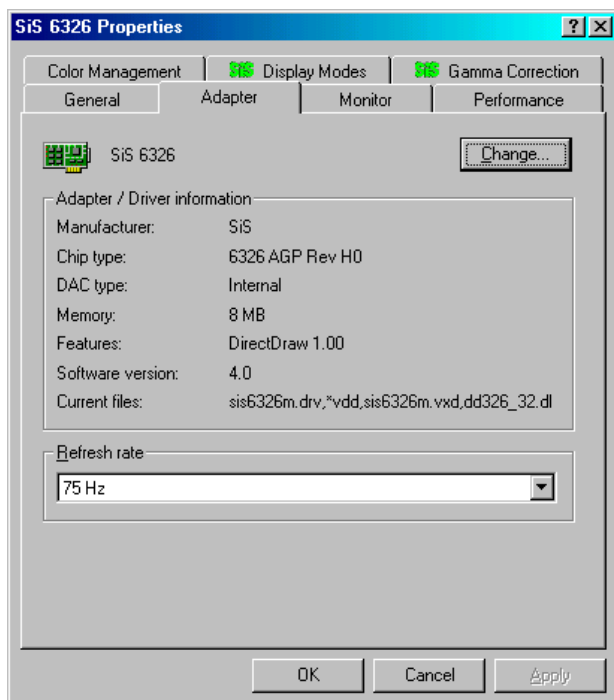

3. Press “Next,” then “Display a list....”

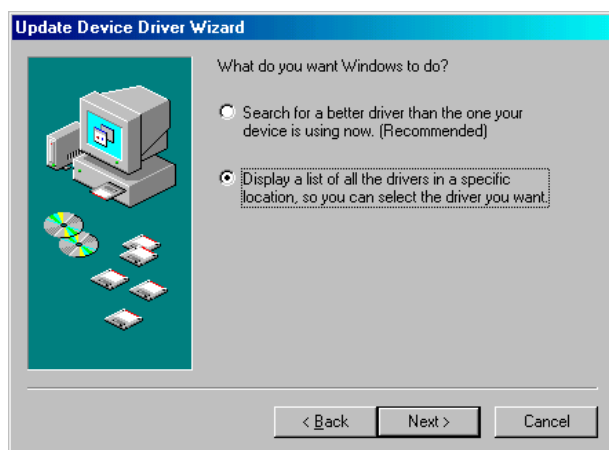

4. Press the “Have disk...” button.

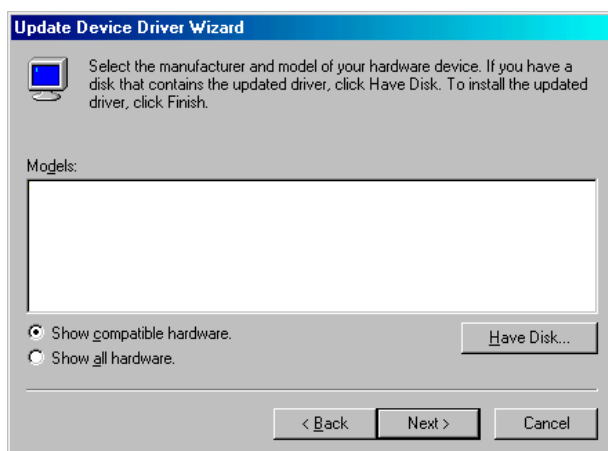

5. Insert the CD into the CD-ROM drive. Type in the path **D:\vga\VT8606\Win9x_Me**
Then press “OK”



6. Select the highlighted item, then click “OK.”

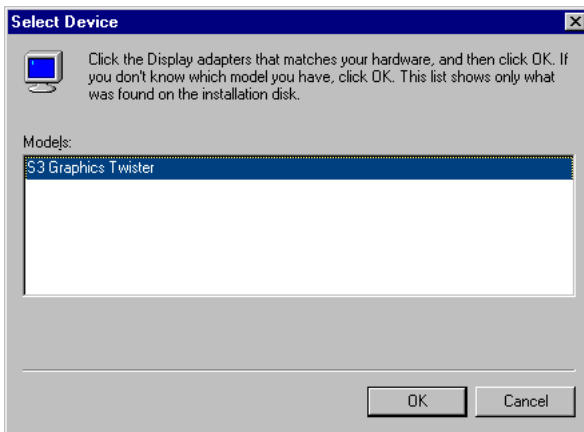

7. "S3 Graphics Twister" appears under the adapter tab. Click the "Apply" button.

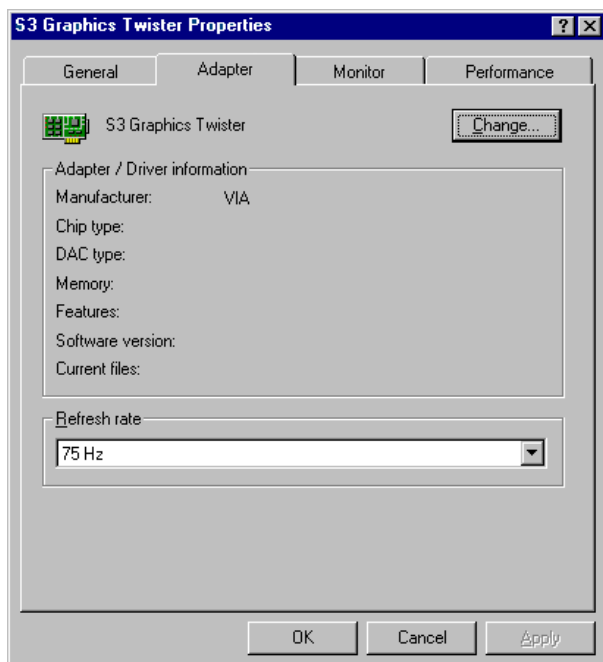

8. Press "Yes" to reboot.

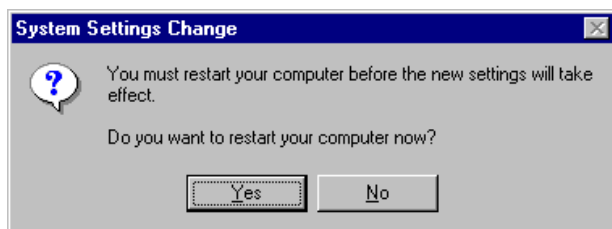

5.2.3 Installation for Windows NT

Note: Service Pack X (X = 3, 4, 5, 6,...) must be installed first, before you install the Windows NT VGA driver.

1. Select "Start", "Settings", "Control Panel" and double click the "Display" icon.

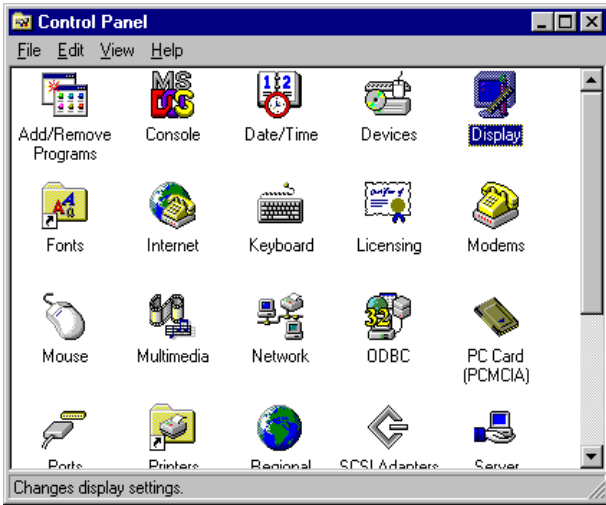

2. Choose the "Settings" tab, and press the "Display Type" button.

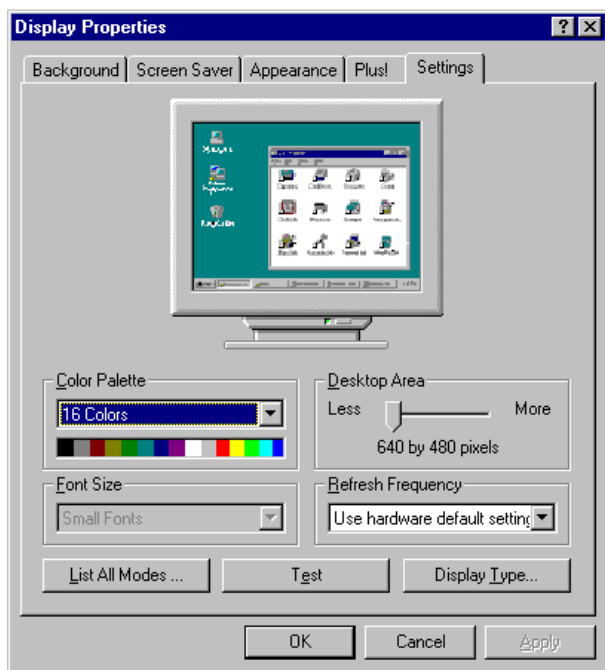

3. Press the "Change..." button.

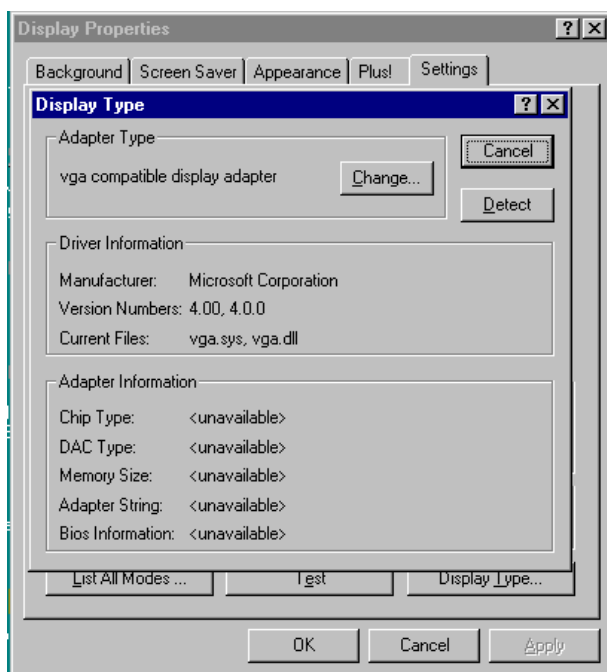

- Click the "Have Disk..." button.

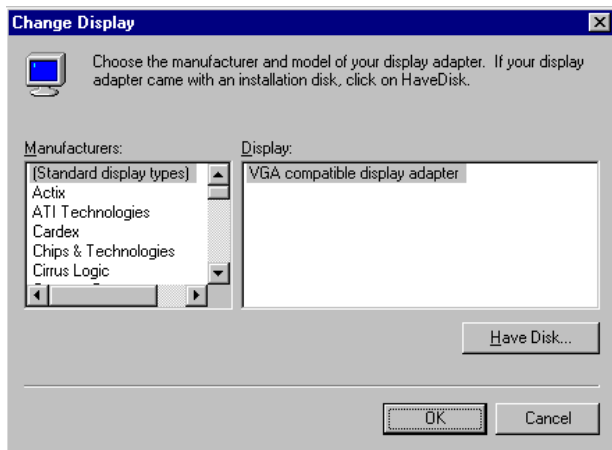

- Type the path:
D:\vga\VT8606\Win NT
Press the "OK" button.

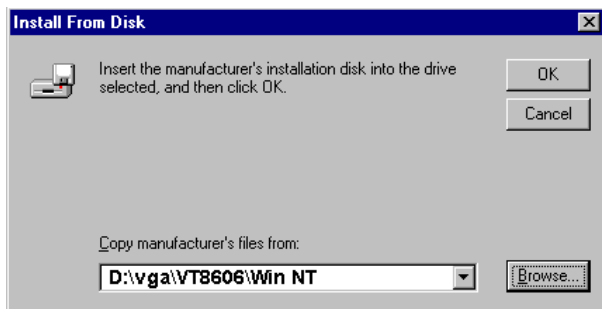

6. Select the highlighted item, and click the "OK" button.

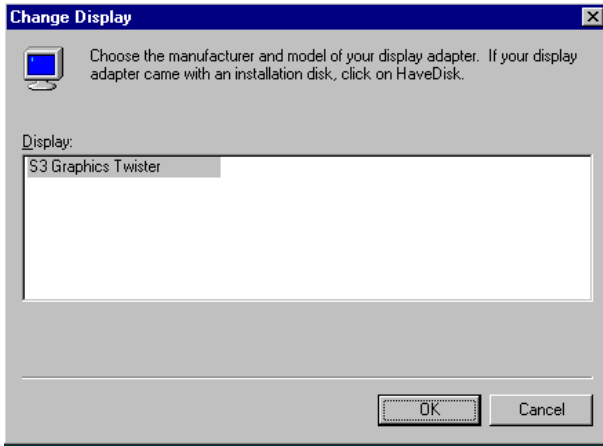

7. Press "Yes" to proceed.



8. Press "OK" to reboot.

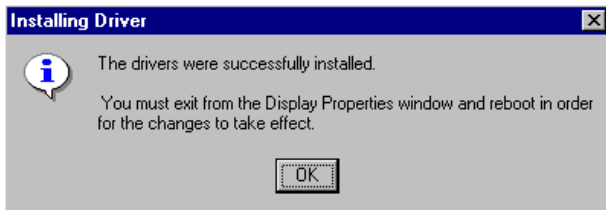

5.2.4 Installation for Windows 2000

1. Select "System", "Settings", "Control Panel" and double click the "system" icon.

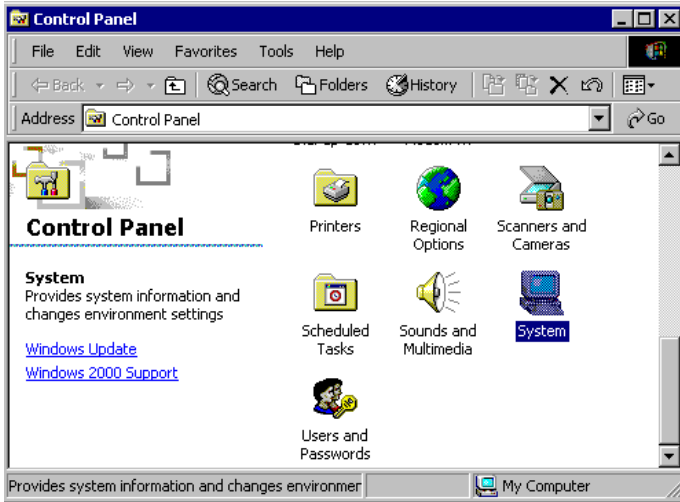

2. Choose the "Video Controller (VGA Compatible)" button.

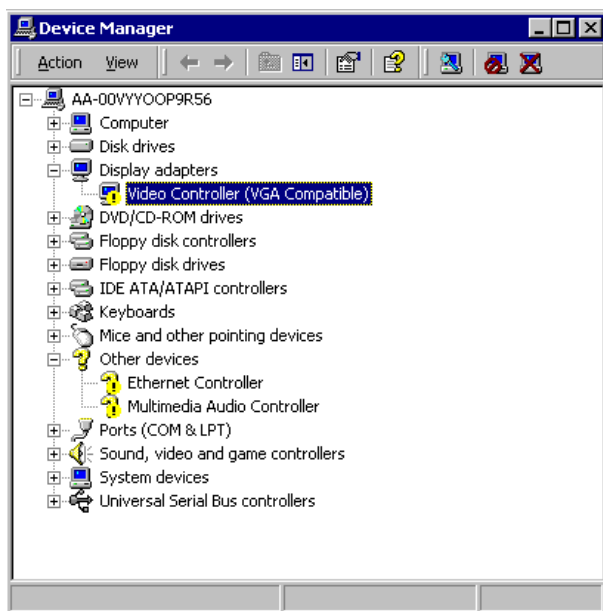

3. Choose the "Drive" button, press "Update Driver..." button.

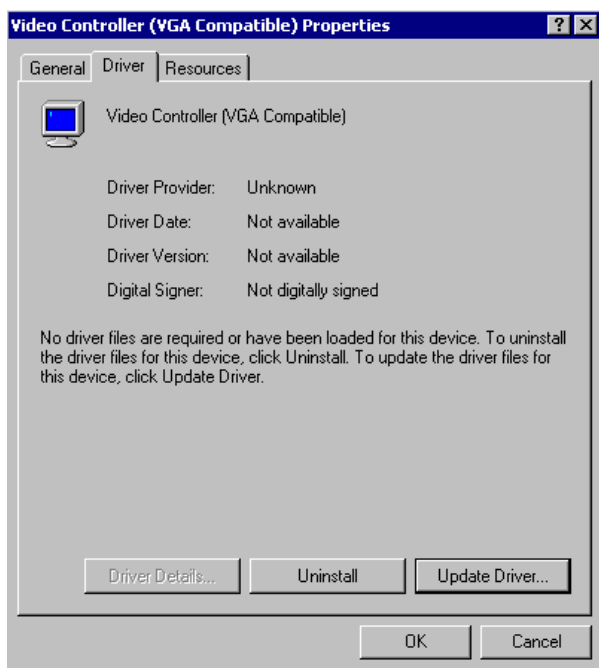

4. Choose "Display a list of..." , then press "Next" button.



5. Choose "Display adapters", press "Next" button.

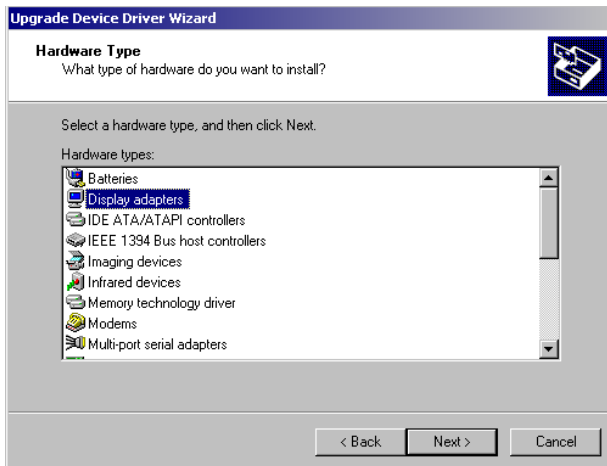

6. Click the “Have Disk” button.

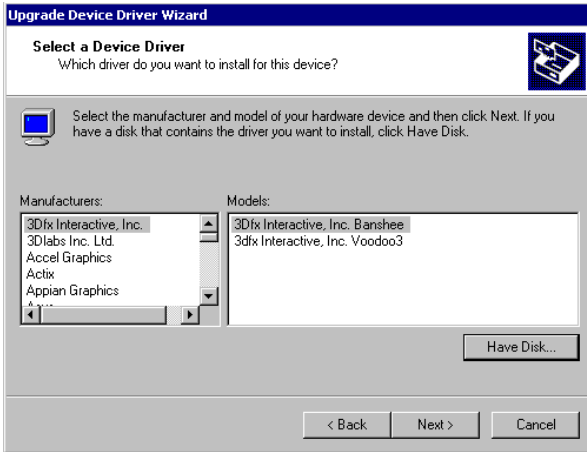

7. Type the path `D:\vga\VT8606\Win2000` press the “OK” button.



8. Press "Finish" to reboot.



5.2.5 Installation for Windows XP

1. Select "System", "Settings", "Control Panel" and double click the "system" icon.

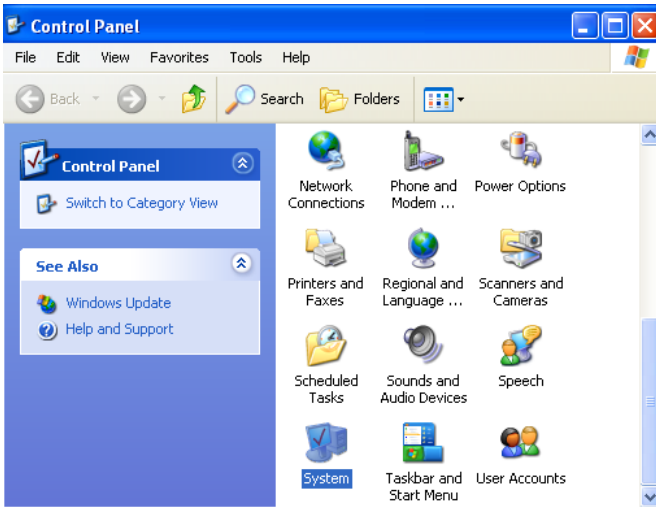

2. Choose “Hardware” and “Device Manager”, press “OK” button.

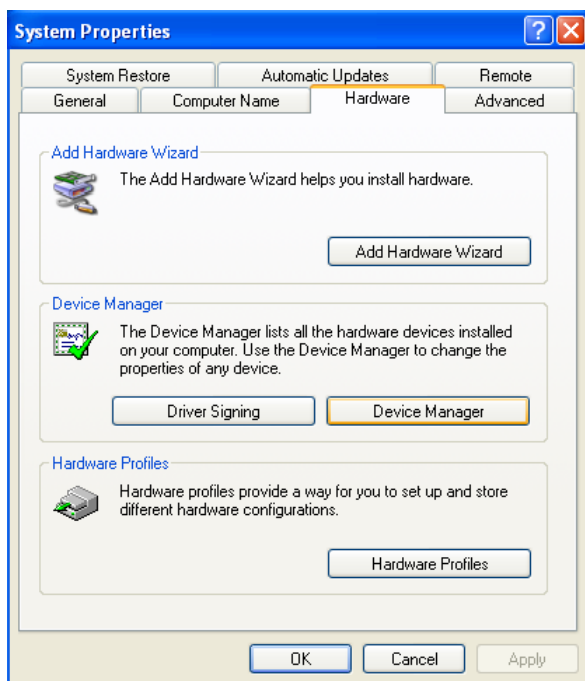

3. Choose “Video Controller (VGA Compatible), press “OK” button.

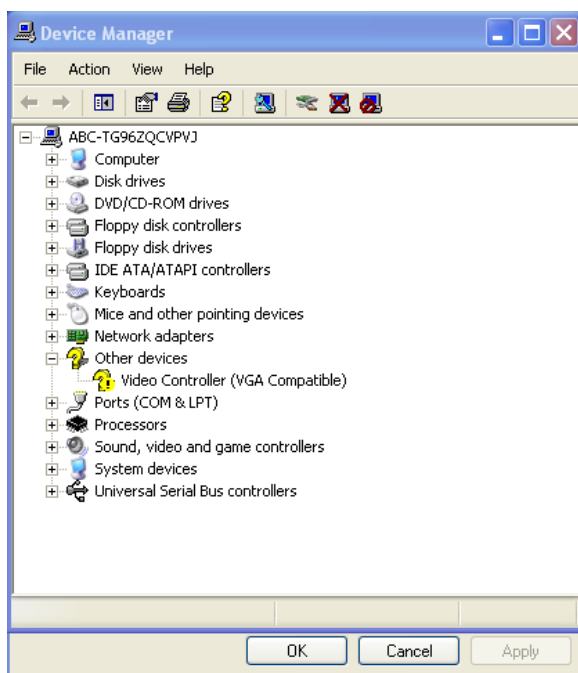

4. Choose "Driver", "Update Driver", press "OK" button.

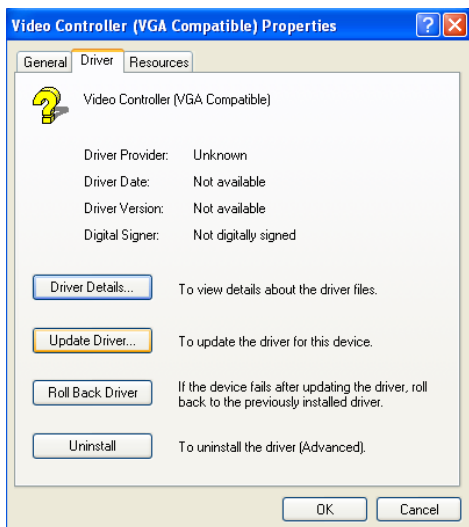

5. Choose "Install from a list.....", press "Next".

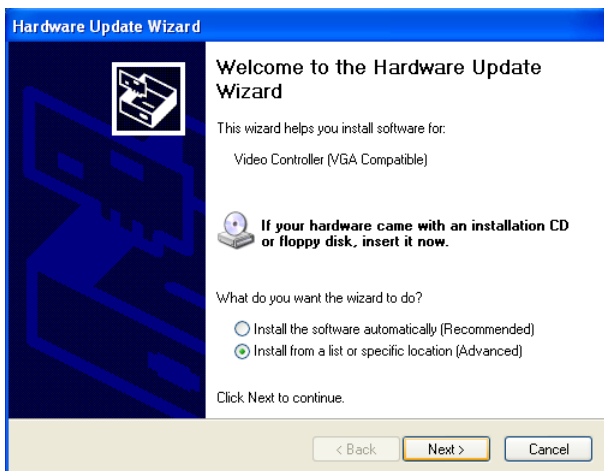

6. Choose “Don’t search. I will...”, press “Next” button.

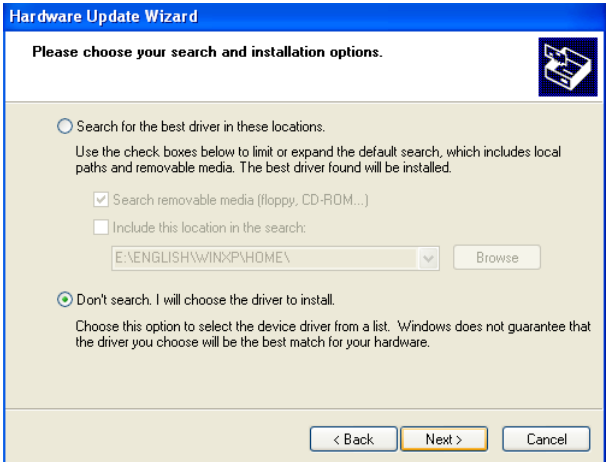

7. Choose “Display adapters”, press “Next” button.

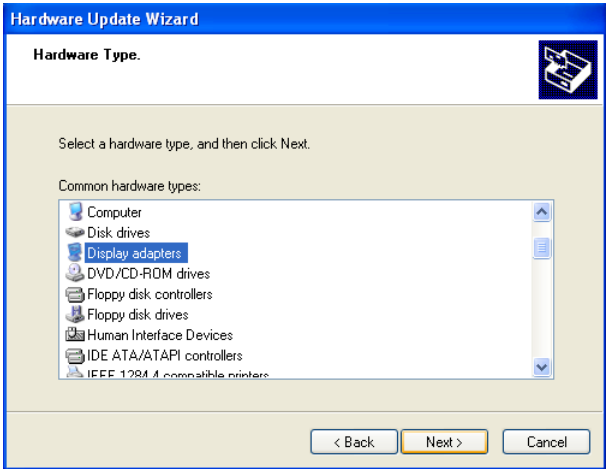

8. Type the path D:\vga\VT8606\WinXP then press “OK” button.

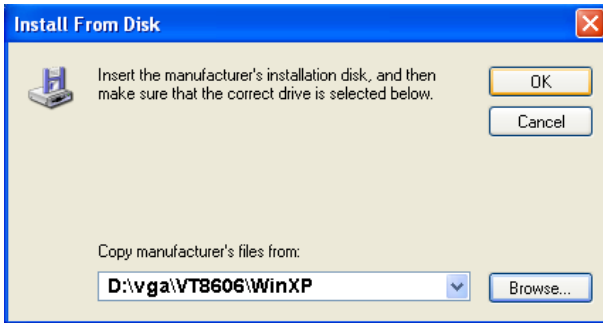

9. Choose “S3 Graphics Twister + S3 Hotkey” then press “Next” button.

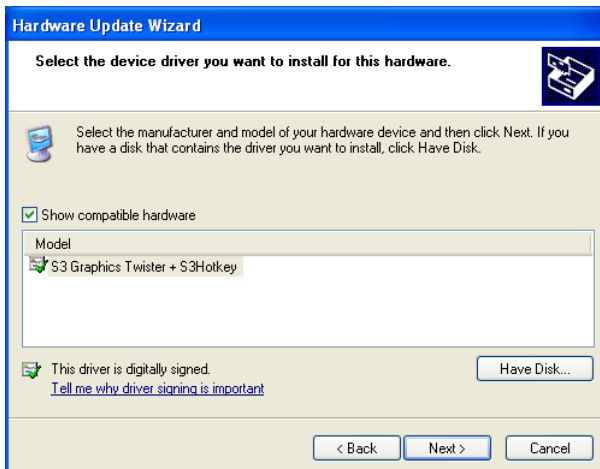

10. Press "Finish" to reboot.

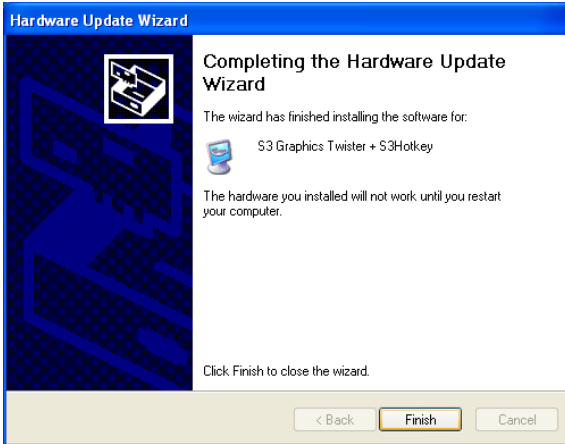

5.3 Further Information

For further information about the AGP/VGA installation in your PCM-3370, including driver updates, troubleshooting guides and FAQ lists, visit the following web resources:

VIA website: www.via.com.tw

Advantech websites: www.advantech.com
www.advantech.com.tw

PCI Bus Ethernet Interface

This chapter provides information on Ethernet configuration.

- Introduction
- Installation of Ethernet driver for
 - MS-DOS
 - Windows 3.1
 - Windows 95
 - Windows 98
 - Windows 2000
 - Windows NT
- Further information

Chapter 6 PCI Bus Ethernet Interface

6.1 Introduction

The PCM-3370 is equipped with a high-performance 32-bit Ethernet chipset which is fully compliant with IEEE 802.3 100 Mbps CSMA/CD standards. It is supported by major network operating systems. It is also both 100Base-T and 10Base-T compatible. The medium type can be configured via the PQ8139.exe program included on the utility disk.

The Ethernet port provides a standard RJ-45 jack. The network boot feature can be utilized by incorporating the boot ROM image files for the appropriate network operating system. The boot ROM BIOS files are combined with system BIOS, which can be enabled/disabled in the BIOS setup.

6.2 Installation of Ethernet Driver

Before installing the Ethernet driver, note the procedures below. You must know which operating system you are using in your PCM-3370, and then refer to the corresponding installation flow chart. Then just follow the steps described in the flow chart. You will quickly and successfully complete the installation, even if you are not familiar with instructions for MS-DOS or Windows.

Note: The windows illustrations in this chapter are examples only. You must follow the flow chart instructions and pay attention to the instructions which then appear on your screen.

6.2.1 Installation for MS-DOS and Windows 3.1

If you want to set up your Ethernet connection under the MS-DOS or Windows 3.1 environment, you should first check your server system model. For example, MS-NT, IBM-LAN server, and so on.

Then choose the correct driver to install in your panel PC.

The installation procedures for various servers can be found on CD-ROM. The file path begins as: D:\LAN\8139C\drive\wfw311

6.2.2 Installation for Windows 95

1. a. Select Start/Settings/Control Panel
- b. Double click "Network".

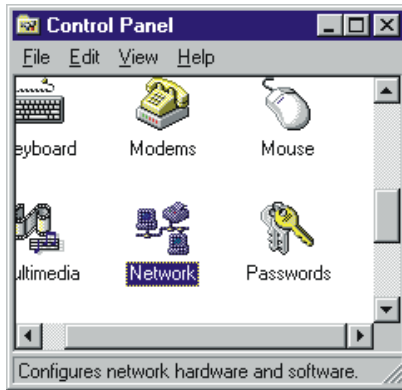

2. a. Click "Add" and prepare to install network functions.

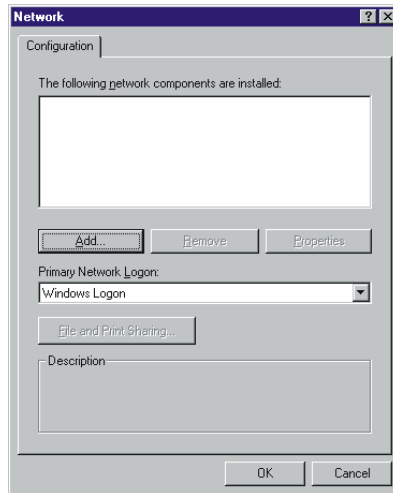

3. a. Select the "Adapter" item to add the Ethernet card.

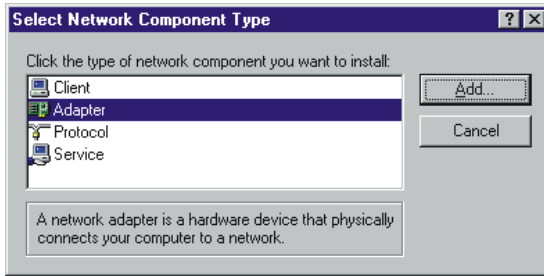

4. Click "Have Disk" to install the driver.

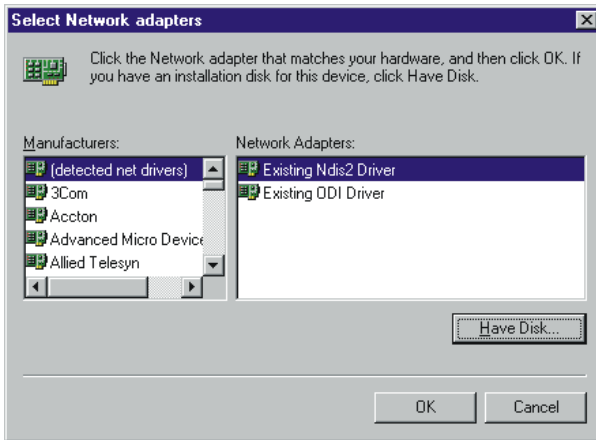

5. a. Insert the CD into the D: drive
b. Fill in: D:\LAN\8139C\
c. Click "OK"



- 6. a. Choose the "Realtek" item
- b. Click "OK"



- 7. a. Make sure the configurations of relative items are set correctly
- b. Click "OK" to reboot

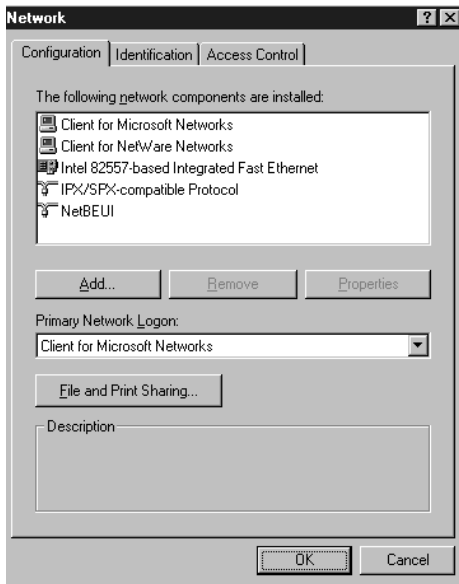

Note: *The correct file path for Windows 98 is:
D:\LAN\8138C\WIN98*

6.2.3 Installation for Windows 2000

Step 1. Open Device Manager,

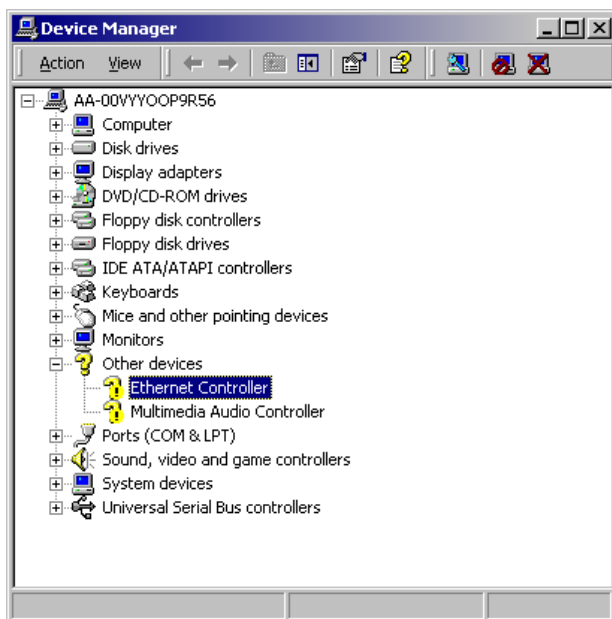

Step 2.

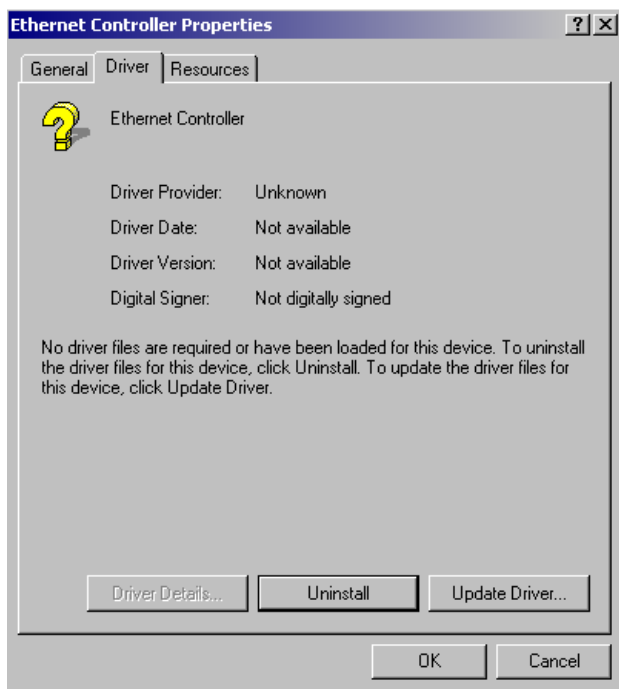

Step 3.



Step 4.



Step 5.

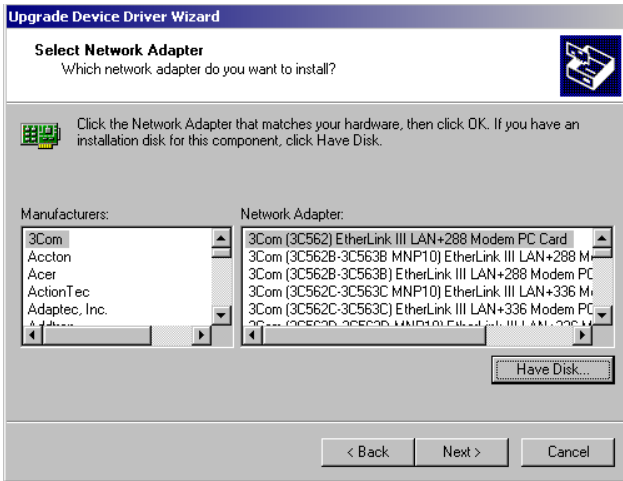

Step 6.

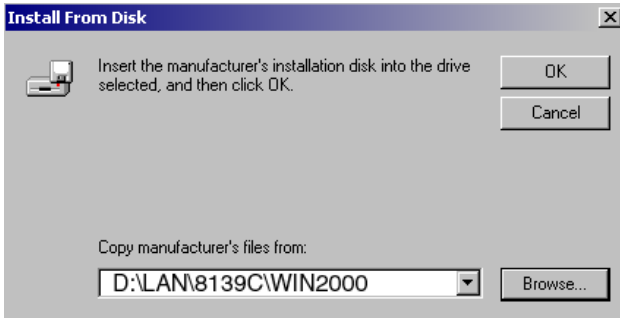

Step 7.

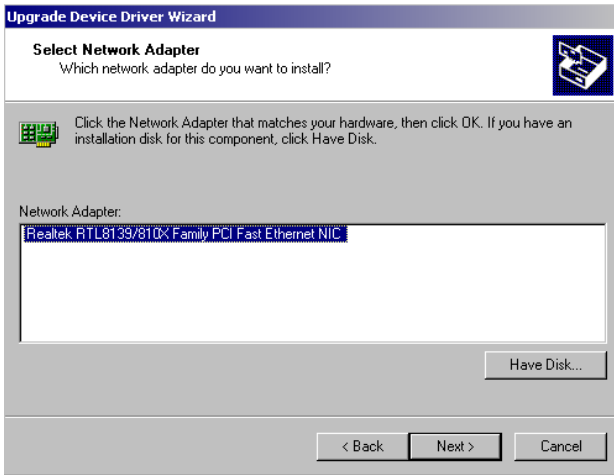

Step 8.



Step 9

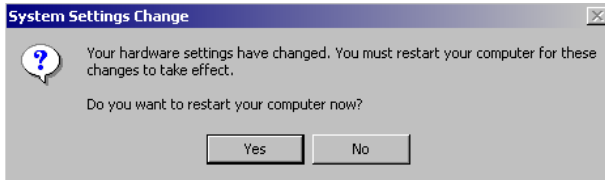

6.2.4 Installation for Windows NT

1. a. Select Start/Settings/Control Panel.
b. Double click "Network".

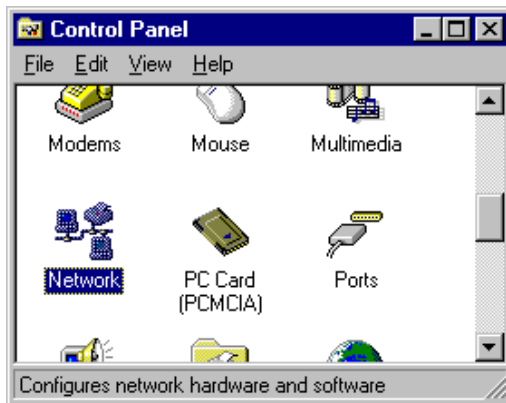

2.
 - a. Choose the "Adapters" label.
 - b. Click the "Add" button.

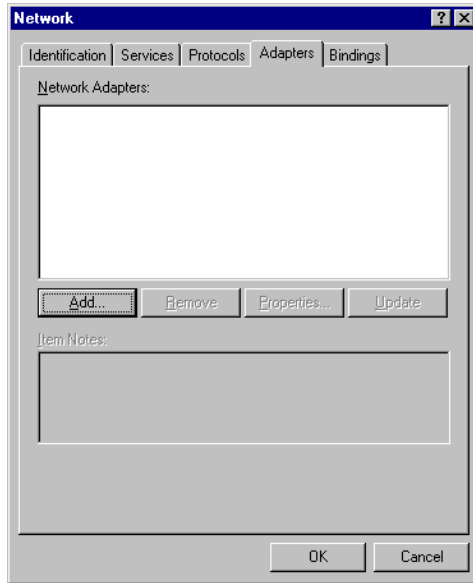

- 3 a. Press "Have Disk".

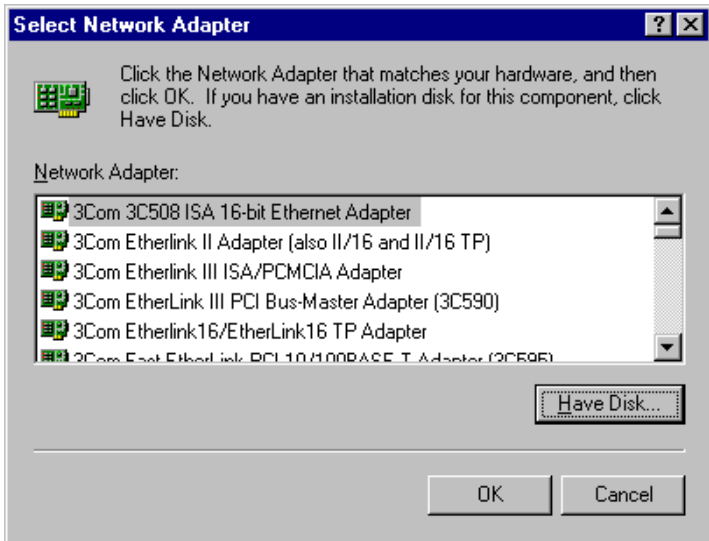

4. a. Type "D:".
b. Press "OK".

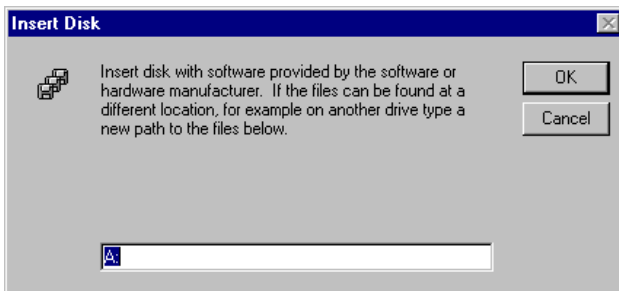

5. a. Insert the CD into the D: drive.
b. Fill in: D:\LAN\8139C\WINNT4
c. Press the "OK" button.

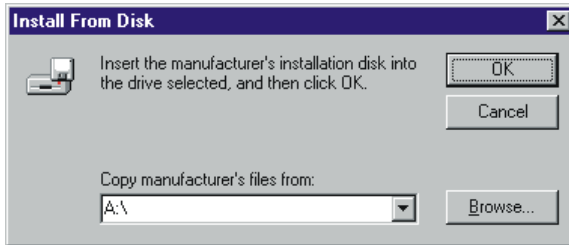

6. a. Choose the "Realtek" item.
b. Press the "OK" button.

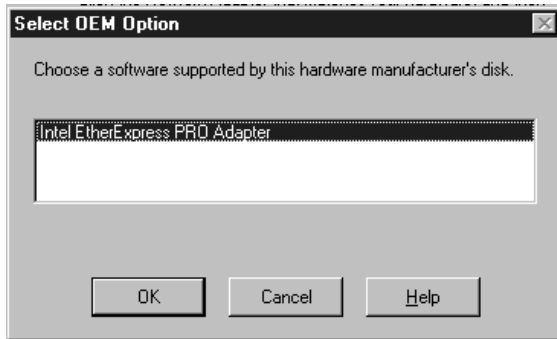

7. a. Make sure the configurations of relevant items are set correctly.
b. Press the "OK" button to reboot.

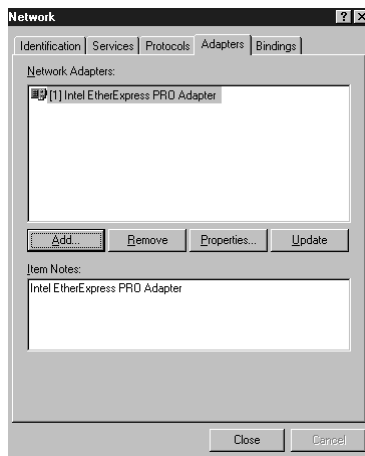

6.3 Further information

Realtek website: www.realtek.com

Advantech websites: www.advantech.com

www.advantech.com.tw

Programming the Watchdog Timer

The PCM-3370 is equipped with a watchdog timer that resets the CPU or generates an interrupt if processing comes to a standstill for whatever reason. This feature ensures system reliability in industrial standalone or unmanned environments.

Appendix A Programming the Watchdog Timer

A.1 Programming the watchdog timer

The following example show how you might program the watchdog timer in Assembly:

1. Watch Dog Timer Enable

Port 404e Bit7 set "o" to enable PCM-3370 Watch Dog Timer

Ex:

```
Mov DX, 404e  
Mov AL, 7F  
Out DX, AL
```

2. Watch Dog Timer Disable

Port 404e Bit6 set "o" to disable PCM-3370 Watch Dog Timer

Ex:

```
Mov DX, 404e  
Mov AL, BF  
Out DX, AL
```

Jumper Settings

The PCM-3370 is equipped with a watchdog timer that resets the CPU or generates an interrupt if processing comes to a standstill for any reason. This feature ensures system reliability in industrial standalone or unmanned environments.

Appendix B PCM-3370F Jumper Settings

1.	CN1	Reset Connect
2.	CN2	Invert Power Connect
3.	CN3	IR Connect
	CN4	FAN Connector
5.	CN5	LAN Connector
6.	CN6	422/485 Connect
7.	CN7	40-pin LCD Port (24bit)
8.	CN8	CRT Connect
9.	CN9	USB Connector
10.	CN10	20-Pin LCD Connector (36-bit)
11.	CN11	PC/104+ Connector
12.	CN12	44-Pin IDE Connector
13.	CN13	COM2 RS232 Connector
14.	CN14	LPT Connector
15.	CN15	Power Connector
16.	CN16	COM1 RS232 Connector
17.	CN17	KB/MS Connector
18.	CN18	ATX Power Connector
19.	CN19	Power Switch Input
20.	CN20	Negative Power Input
21.	CN21	Compact Flash Slot
22.	CN22	RTC Connector
23.	JP1	CMOS Charge&Discharge
24.	JP2	Watchdog Timer
25.	JP3	PCI VIOS SELECT
26.	JP4	COM1, RI Input Select
27.	JP5	COM2 RI Input Select

B.1 CN1 Reset Connector

Table B.2: CN1 Reset Connector

Pin	Pin name
1	Signal
2	GND

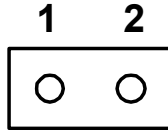

B.2 CN2 Inverter Power Connector

Table B.3: CN2 Inverter Power Connector

1	+12V
2	GND
3	ENABKL
4	VBR
5	+5V

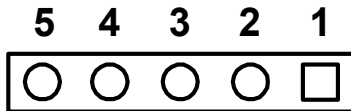

B.3 CN3 IR Connector

Table B.4: IR Connector

1	+5V
2	NC
3	IRRX
4	GND
5	IRTX

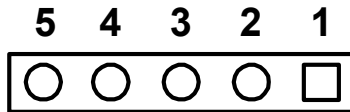

B.4 CN4 FAN Connector

Table B.5: CN4 FAN Connector

1	SPEED DETECT
2	+5V
3	GND

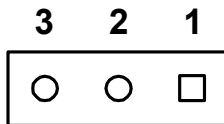

B.5 CN5 LAN Connector

Table B.6: CN5 LAN Connector

Pin	Pin name
1	VCC_LAN
2	ACTLED
3	RX+
4	RX-
5	LILED
6	GND
7	NC
8	GND
9	TX+
10	TX-

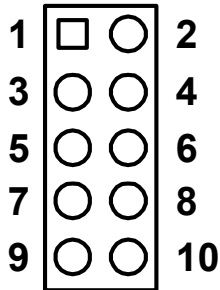

B.6 CN6 422/485 Connector

Table B.7: CN6 422/485 Connector

1	RX485-
2	RX485+
3	TX485+
4	TX485-

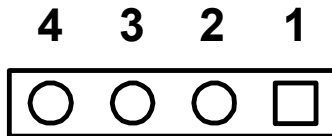

B.7 CN7 40-Pin LCD Port (24bit)

Table B.8: CN7 40-Pin LCD Port (24bit)

Pin	Pin name	Pin	Pin name
1	LCD VDD(+5V)	2	LCD VDD(+5V)
3	GND	4	GND
5	LCD VDD(+3.3V)	6	LCD VDD(+3.3V)
7	Vcon(optional)	8	GND
9	PD0	10	PD1
11	PD2	12	PD3
13	PD4	14	PD5
15	PD6	16	PD7
17	PD8	18	PD9
19	PD10	20	PD11
21	PD12	22	PD13
23	PD14	24	PD15
25	PD16	26	PD17
27	PD18	28	PD19
29	PD20	30	PD21
31	PD22	32	PD23
33	GND	34	GND

35	SHFCLK	36	FLM(V-SYNC)
37	M/(DE)	38	LP(H-SYNC)
39	ENABKL	40	ENVEE

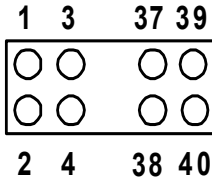

B.8 CN8 CRT Connector

Table B.9: CN8 CRT Connector

1	RED
2	DDC POWER(+5V)
3	GREEN
4	GND
5	BLUE
6	NC
7	NC
8	DDC DATA
9	GND
10	H-SYNC
11	GND
12	V-SYNC
13	GND
14	DDC CLOCK
15	GND
16	NC

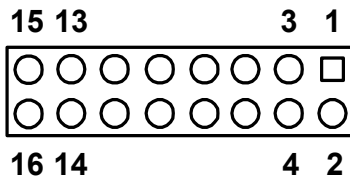

B.9 CN9 USB Connector

Table B.10: CN9 USB Connector

1	+5V
2	+5V
3	D0-
4	D1-
5	D0+
6	D1+
7	GND
8	GND
9	GND
10	NC

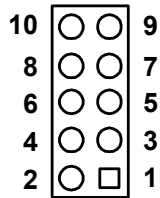

B.10 CN10 20-Pin LCD Connector (36-bit)

Table B.11: CN10 20-Pin LCD Connector (36-bit)

Pin	Pinname	Pin	Pinname
1	GND	2	GND
3	PD24	4	PD25
5	PD26	6	PD27
7	PD28	8	PD29
9	PD30	10	PD31
11	PD32	12	PD33
13	PD34	14	PD35
15	GND	16	GND
17	NC	18	SPCLK
19	PCIRST	20	SPDAT

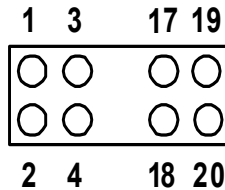

B.11 CN11 PC/104+ Connector

Table B.12: PC/104+ connectors (CN18)

Pin Number	Signal RowA	Signal Row B	Signal RowC	Signal RowD
1	IOCHCHK*	GND	GND	GND
2	SD7	RESET	SBHE*	MEMCS16*
3	SD6	+5 V	LA23	IOCS16*
4	SD5	IRQ9	LA22	IRQ10
5	SD4	-5V	LA21	IRQ11
6	SD3	DRQ2	LA20	IRQ12
7	SD2	-12V	LA19	IRQ15
8	SD1	ENDXFR*	LA18	IRQ14

9	SD0	+12V	LA17	DACK0*
10	IOCHRDY	(KEY)	MEMR*	DRQ0
11	AEN	SMEMW*	MEMW*	DACK5*
12	SA19	SMEMR*	SD8	DRQ5
13	SA18	IOW*	SD9	DACK6*
14	SA17	IOR*	SD10	DRQ6
15	SA16	DACK3*	SD11	DACK7*
16	SA15	DRQ3	SD12	DRQ7
17	SA14	DACK1*	SD13	+5V
* low active				
18	SA13	DRQ1	SD14	MASTER*
19	SA12	REFRESH*	SD15	0V
20	SA11	SYSCLK	(KEY)	0V
21	SA10	IRQ7	----	----
22	SA9	IRQ6	----	----
23	SA8	IRQ5	----	----
24	SA7	IRQ4	----	----
25	SA6	IRQ3	----	----
26	SA5	DACK2*	----	----
27	SA4	TC	----	----
28	SA3	BALE	----	----
29	SA2	+5V	----	----
30	SA1	OSC	----	----
31	SA0	0V	----	----
32	0V	0V	----	----

CN18 ISA bus long side

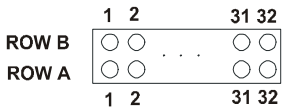

CN18 ISA bus short side

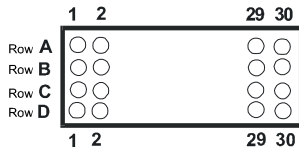
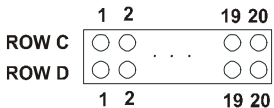

PC/104-Plus connector (PCI bus)

B.12 CN12 44-Pin IDE Connector

Table B.13: CN12 44-Pin IDE Connector

Pin	Pinname	Pin	Pinname
1	Reset	2	GND
3	D7	4	D8
5	D6	6	D9
7	D5	8	D10
9	D4	10	D11
11	D3	12	D12
13	D2	14	D13
15	D1	16	D14
17	D0	18	D15
19	GND	20	Reserved
21	DMARQ	22	GND
23	DIOW-	24	GND
25	DIOR-	26	GND
27	IORDY	28	SPSYNC:CSEL
29	DMACK-	30	GND
31	INTRQ	32	IOCS16#
33	DA1	34	PDIAG#:N/C
35	DA0	36	DA2
37	CS0-	38	CS1-
39	DASP-	40	GND
41	+5V	42	+5V
43	GND	44	NC

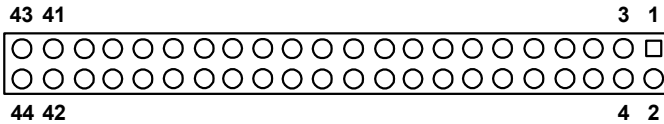

B.13 CN13 COM2 RS232 Connector

Table B.14: CN13 COM2 RS232 Connector

Pin	Pin name
1	DCD
2	DSR
3	RxD
4	RTS
5	TxD
6	CTS
7	DTR
8	RI
9	GND
10	N/C

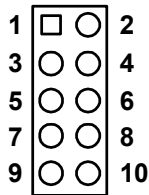

B.14 CN14 LPT Connector

Table B.15: CN14 LPT Connector

Pin	Pin name	Pin	Pin name
1	STROBE-	2	AUTO FEED-
3	Data 0	4	ERROR
5	Data 1	6	INIT-
7	Data 2	8	SLCT IN-
9	Data 3	10	GND
11	Data 4	12	GND
13	Data 5	14	GND
15	Data 6	16	GND

17	Data 7	18	GND
19	ACK-	20	GND
21	BUSY	22	GND
23	PaperEmpty	24	GND
25	SELECT	26	N/C

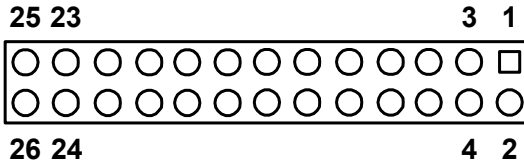

B.15 CN15 Power Connector

Table B.16: CN15 Power Connector

1	+5V
2	+5V
3	+5V
4	GND
5	GND
6	GND
7	GND
8	+12V



B.16 CN16 COM1 RS232 Connector

Table B.17: CN16 COM1 RS232 Connector

Pin	Pin name
1	DCD
2	DSR
3	RXD
4	RTS
5	TXD
6	CTS
7	DTR
8	RI
9	GND
10	N/C

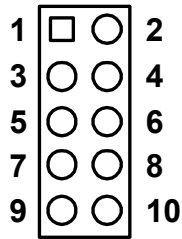

B.17 CN17 KB/MS Connector

Table B.18: CN17 KB/MS Connector

Pin	Pin name
1	KB CLOCK
2	KB DATA
3	MS CLOCK
4	GND
5	+5V
6	MS DATA

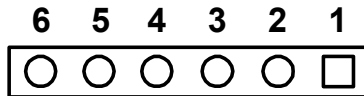

B.18 CN18 ATX Power Connector

Table B.19: CN18 ATX Power Connector

Pin	Pin name
1	+5V Standby
2	GND
3	PSON

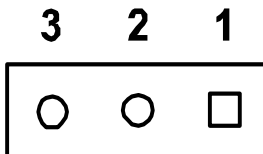

B.19 CN19 Power Switch Connector

Table B.20: CN19 Power Switch Connector

Pin	Pin name
1	Signal
2	GND

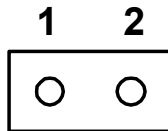

B.20 CN20 Negative Power Input

Table B.21: CN20 Negative Power Input

Pin	Pin name
1	-5V
2	GND
3	-12V

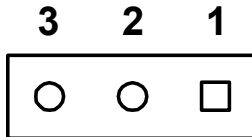

B.21 CN21 Compact Flash Slot

Table B.22: CompactFlash socket (CN21)

Pin	Signal	Pin	Signal
1	GND	2	D03
3	D04	4	D05
5	D06	6	D07
7	*CS0	8	A10
9	*ATA SEL	10	A09

11	A08	12	A07
13	+5 V	14	A06
15	A05	16	A04
17	A03	18	A02
19	A01	20	A00
21	D00	22	D01
23	D02	24	*IOCS16
25	*CD2	26	*CD1
27	D11	28	D12
29	D13	30	D14
31	D15	32	*CS1
33	*VS1	34	*IORD
35	*IOWR	36	*WE
37	INTRQ	38	+5 V
39	*CSEL	40	*VS2
41	*RESER	42	IORDY
43	*INPACK	44	*REG
45	*DASP	46	*PDIAG
47	D08	48	D09
49	D10	50	GND

* low active

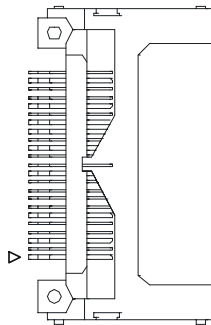

B.22 CN22 RTC Connector

Table B.23: CN22 RTC Connector

Pin	Pin name
1	Signal
2	GND

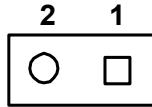

B.23 JP1 COMS Charge&Discharge

Table B.24: JP1 COMS Charge&Discharge

Pin	Function
1-2	Charge *
2-3	Discharge

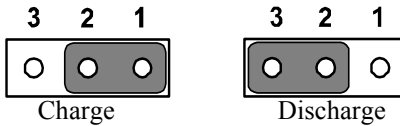

B.24 JP2 Watchdog Timer

Table B.25: JP2 Watchdog Timer

Pin	Function
1-2	Reset *
2-3	IRQ11

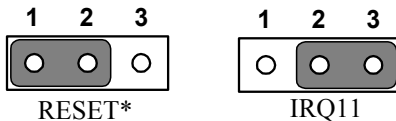

B.25 JP3 PCI VIO Select

Table B.26: JP3 PCI VIO Select

Pin	Function
1-2	VCC
2-3	VCC3
Default	NULL *

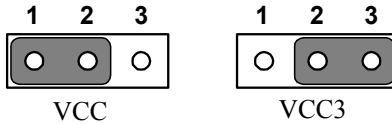

B.26 JP4 COM1 RI Input Select

Table B.27: JP4 COM1 RI Input Select

Pin	Function
1-2	RI *
2-3	VCC

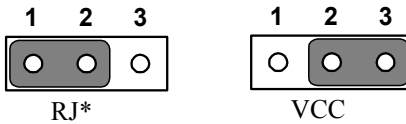

B.27 JP5 COM2 RI Input Select

Table B.28: JP5 COM2 RI Input Select

Pin	Function
1-2	RI *
2-3	VCC

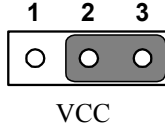
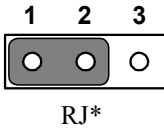

System Assignments

- System I/O ports
- DMA channel assignments
- Interrupt assignments

Appendix C System Assignments

C.1 System I/O ports

Table C.1: System I/O ports

Addr. range	
(Hex)	Device
000-01F	DMA controller (slave)
020-03F	Interrupt controller 1, (master)
040-05F	8254 timer/counter
060-06F	8042 (keyboard controller)
070-07F	Real-time clock, non-maskable interrupt (NMI) mask
080-09F	DMA page register,
0A0-0BF	Interrupt controller 2 (slave)
0C0-0DF	DMA controller (master)
0F0	Clear math co-processor
0F1	Reset math co-processor
0F8-0FF	Math co-processor
1F0-1F8	1st fixed disk
200-207	Game I/O
278-27F	Reserved
2F8-2FF	Serial port 2
300-31F	Ethernet**
360-36F	LPT2
378-37F	Parallel printer port 1 (LPT1)
380-38F	SDLC, bisynchronous 2
3A0-3AF	Bisynchronous 1
3B0-3BF	Monochrome display
3C0-3CF	Reserved
3D0-3DF	Color/graphics monitor adapter
3F0-3F7	Diskette controller
3F8-3FF	Serial port 1

443	Watchdog timer
-----	----------------

** default setting

C.2 DMA channel assignments

Table C.2: DMA channel assignments

Channel	Function
0	Available
1	Available
2	Floppy disk (8-bit transfer)
3	Parallel**
4	Cascade for DMA controller 1
5	Available
6	Available
7	Available

** Parallel port DMA default setting: DMA 3

Parallel port DMA select: DMA 1, 3

C.3 Interrupt assignments

Table C.3: Interrupt assignments

Interrupt#	Interrupt source
NMI	Parity error detected
IRQ 0	Interval timer
IRQ 1	Keyboard
IRQ 2	Interrupt from controller 2 (cascade)
IRQ 3	Serial communication port 2
IRQ 4	Serial communication port 1
IRQ 5	Available
IRQ 6	Diskette controller (FDC)
IRQ 7	Parallel port 1 (print)IRQ 8 Real-time clock
IRQ 8	Real-time clock
IRQ 9	Available
IRQ 10	Available
IRQ 11	Available
IRQ 12	PS/2 mouse (If using PS/2 mouse)
IRQ 13	INT from co-processor
IRQ 14	Preliminary IDE
IRQ 15	Secondary IDE for CompactFlash

* All available IRQ can use for PCI device

* Now onboard PCI device List is USB IRQ 10 USB, IRQ 11 LAN and IRQ 12 ACPI control

C.4 1st MB memory map

Table C.4: 1st MB memory map

Addr. range (Hex)	Device
F000h - FFFFh	System ROM
E000h - EFFFh	Reserved for BIOS boot
CC00h - DFFFh	available
C000h - CB00h	VGA BIOS
B800h - BFFFh	CGA/EGA/VGA text
B000h - B7FFh	Reserved for graphic mode usage
A000h - AFFFh	EGA/VGA graphics
0000h - 9FFFh	Base memory

*default setting
